

2019



EAE Automotive Equipment Company Limited

EAE Wujiang
1089 North Yunlian Rd.Wujiang
Suzhou
Tel 0086-512-63032886

EAE Shanghai
Rm 501,Bldg 2,No.600,West Yunling
Rd.Putuo,Shanghai
Tel/Fax 0086-21-32500750/32500785

EAE UK
3D Vanguard Way, Battlefield Enterprise
Park, Shrewsbury UK SY1 3TG
Tel/Fax 44 844 800 7522/44 844 800 7523



www.eae-ae.com Toll Free Call:400 9911 109 sales@eae-ae.com



EAE



I am a mechanic worker in TNP car refit shop. EAE lift have been running in very good condition for more than four years in our shop, and I feel safe when work under the car.

 EAE

CAUTION

CAUTION

ABOUT US



Since 2003, we, EAE Automotive Equipment Company Limited, with manufacturing facility in Wujiang and over 300 employees, focusing on passenger and commercial vehicle service lifts, have been one of the most professional players in the automotive aftermarket.



In recent years, we have taken great stride in market expansion both overseas and in China. With a complete range of passenger vehicle lifts under 8000KG load capacity and commercial vehicle service lifts under 60Tons that are manufactured in-house at our Wujiang manufacturing facility, our products and solutions have been commissioned in over 90 countries. In addition, we have been exceptionally successful in domestic passenger vehicle lift market, winning numerous awards, projects, approvals, and certifications from a number of car manufacturers.



However, because of our realizing that the market is ever changing and competition increasing, we never ignore our heavy focus in research and development, and product FMEA/longevity testing, product training, and demonstration of our products and solutions.

We hope that you join us in this journey, so that together we can bring our businesses to a new level of success.

EAE is not only your vehicle lift supplier, but your partner.



5/2/2 WARRANTY POLICY
 5 years for lift structure
 2 years for hydraulic components
 2 years for electrical parts

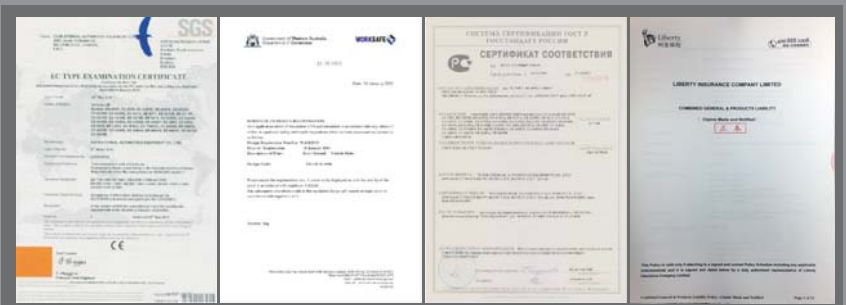

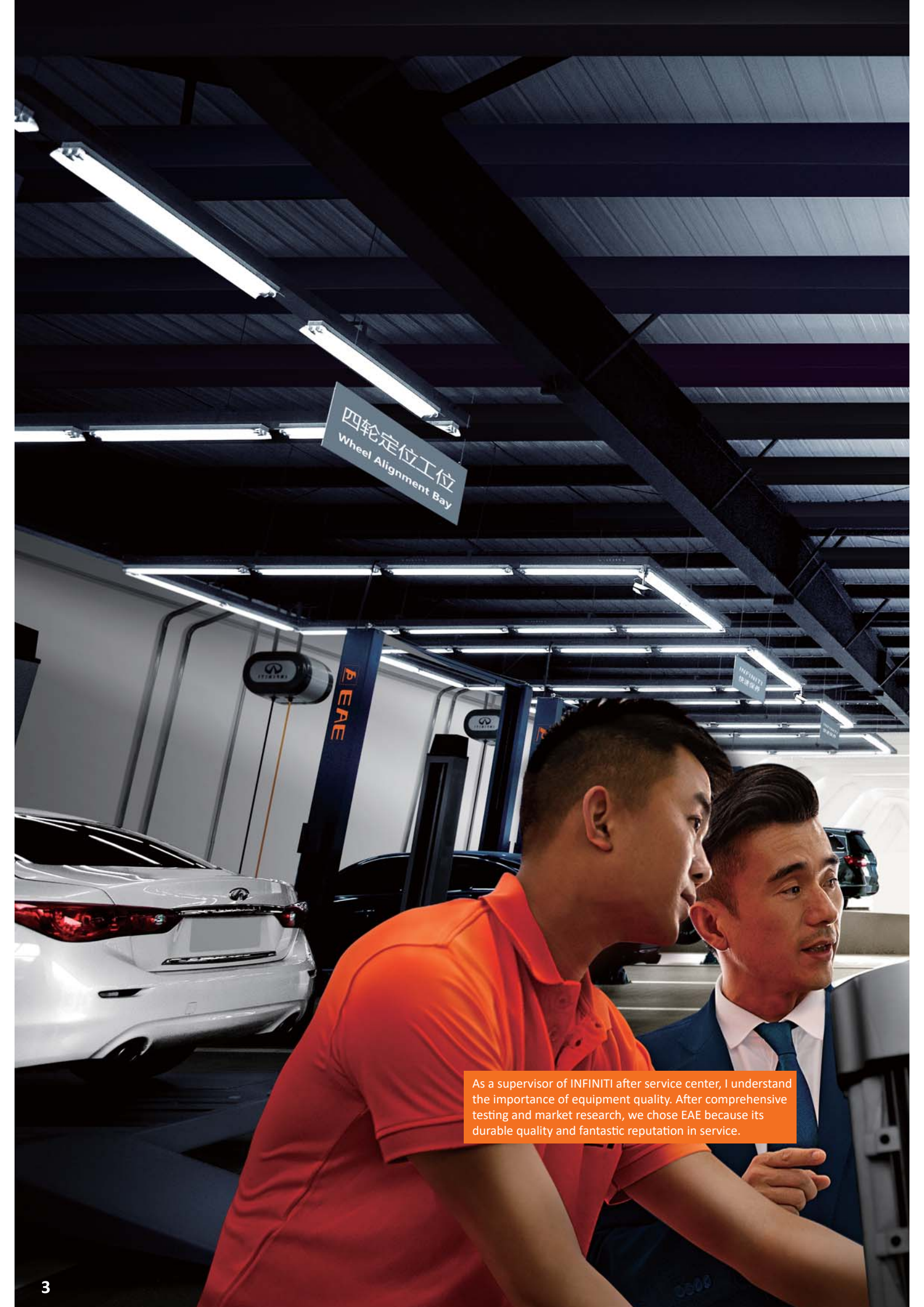

四轮定位工位
Wheel Alignment Bay

As a supervisor of INFINITI after service center, I understand the importance of equipment quality. After comprehensive testing and market research, we chose EAE because its durable quality and fantastic reputation in service.

COMPANY EVENTS

2003

Established EAE Automotive Equipment Company Limited.
(Formerly Known as Ever-Eternal Company Limited.)

2006

Established manufacturing facility in Wujiang, China.



2007

Awarded China's TOP TEN Garage Equipment Brand.
Participated AAPEX in USA and Automechanika Frankfurt.



2009

Launched 5.5T long platform scissor lift.
Started to build distribution channels in China
EAE's second brand-Everet for non-car lift garage
equipment and solution.



2012

Renamed Ever-Eternal as EAE.
Approved by Peugeot DS, GreatWall, Toyota, etc in China.



2014

EAE UK set up.

2016

More car manufacturers, oil companies, tire companies
approvals in China, such as GM, SHELL, RENAULT.
First time show in SEMA USA
Heavy duty two post lift released.



2017

First time show in Autopromotec in Italy and AAE show in Australian.



2018

Mobile column lift and heavy duty scissor lift released.



INDEX



EE-612E/2.5T



EE-612FE/2.5T



EE-C12E/6.0T



EE-6255E/5.0T



EE-6215E/5.0T



EE-6214EKZ/EE-6215EKZ 4.0T/5.0T



EE-62B/3.5T-4.2T



EE-62C/3.5T-4.2T



EE-6435V2/4.0T-5.0T



EE-6435V2.BWF/4.0T-5.0T



EE-6445P/4.0T



EE-4S/4.0T



EE-HX6/6.0T



EE-6604V2/4.0T



EE-6603/4.2T-5.0T



EE-LX35/3.5T



EE-CJ/3.0T



EE-SCJ/3.0T



MOT&ATL LIFTS

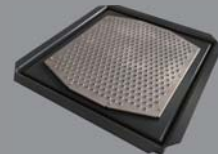

PD

INDEX



EE-65A.40T/4.0T

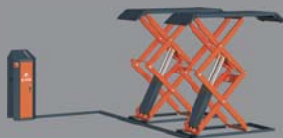

EE-6501V2/3.0T



EE-6503V2/3.5T



EE-MR35/3.5T



EE-MR30/3.0T



EE-TS6600/3.0T



EE-MS12/1.2T



EE-MS10/1.0T

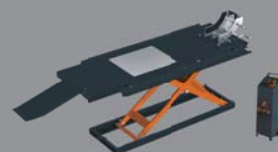

EE-MLH1000/1.0T

Heavy duty



EE-HX15/15T



EE-HDM104/40T



EE-C9/C10 4.0T/4.5T



EE-C12/5.5T



EE-F9/F10/F12 4.0T/4.5T/5.5T



EE-64P2/3.0T

PROCESS FLOW



1
LASER
CUTTING



2
CNC



3
ROBOT
WELDING



4
POWDER
COATING



5
ASSEMBLY
& INSPECTION



6
STORE
HOUSE



7
LOADING
CONTAINER

PROJECT CASES



2500KG | **Swing Arms** | **Button**
 Lifting Capacity | Find Picking Up Points Easily | Control

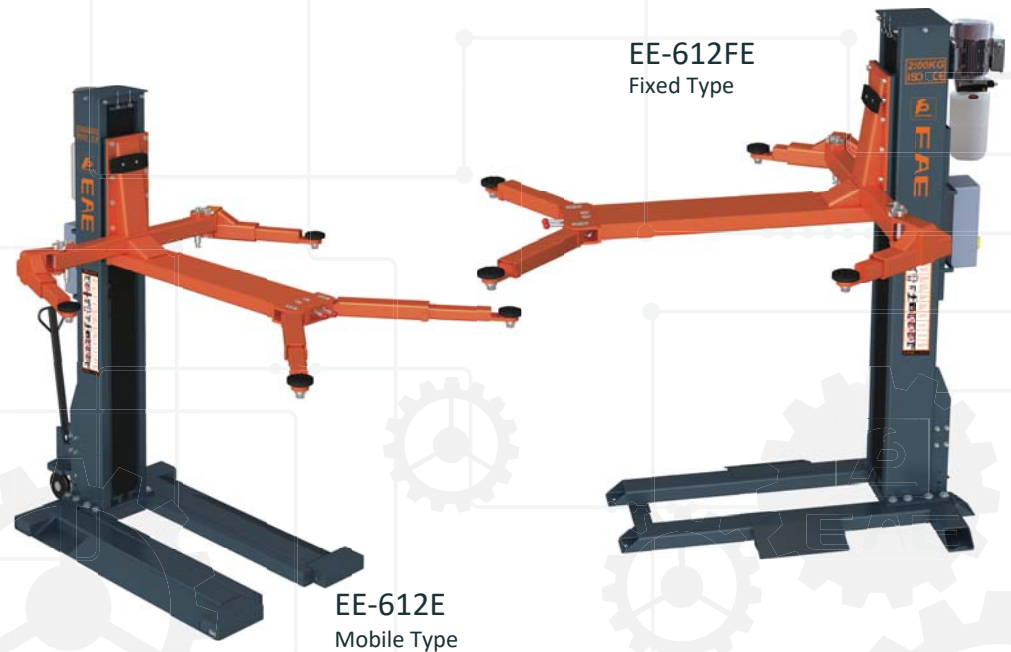

OVERALL DIMENSION

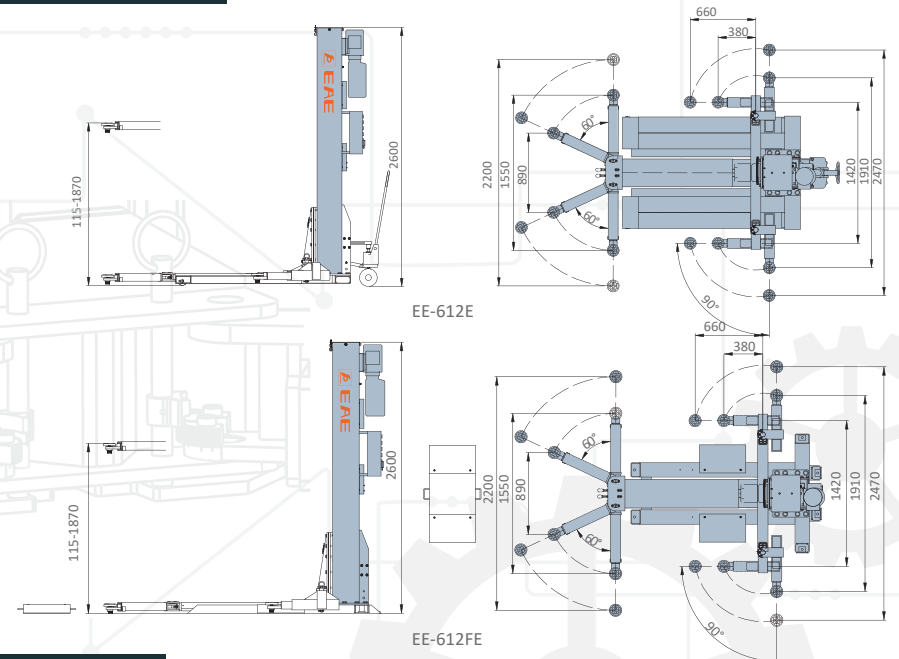

TECHNICAL DATA

MODEL NO.	EE-612E	EE-612FE
Lifting capacity	2500kg	2500kg
Max lifting height	1870mm	1870mm
Min height	115mm	115mm
Lifting time	50S	50S
Motor	2.2kW	2.2kW
Weight	910kg	860kg
Electricity supply	According To Customer Needs	

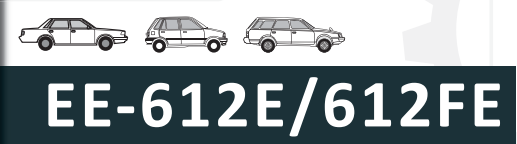

EE-612E/612FE

SINGLE POST LIFT

- CE certified by SGS UK.
- Mobile Positioning based on Pallet Jack System.
- Electrical Safety Lock Release System.
- Aluminum Motor.
- Screw Action Height Adjustable Pads with clearance height ≤115mm.
- Powder Coated Finish.
- Door Protection Pads.
- ABS Control Box.
- Anti-Surge Hydraulic Valve.
- Hydraulic overload protection.
- Reserved Hydraulic Connection for an Optional Manually Operated Pump.
- Installation and Operation Manual and Labels in Chinese, English, Spanish, German, French, Russian, Swedish (Other Languages Available Upon Request).



* Machine shown with optional equipment. Actual product appearance may differ.



6000KG | **110MM** | **2000MM**
 Lifting Capacity | Min. Height | Max. Lifting Height with Standard SUV Adapters



OVERALL DIMENSION

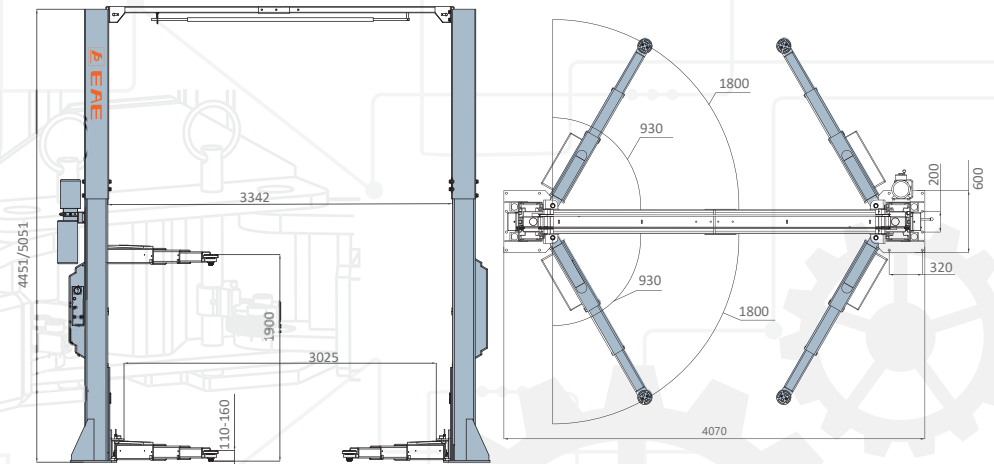

TECHNICAL DATA

MODEL NO.	EE-C12E
Lifting capacity	6,000kg
Max lifting height	1900mm
Min height	110mm
Lifting time	55S
Motor	2.2kW
Rated oil pressure	21MPa
Drive-through width	3025mm
Weight	1400kg
Electricity supply	According To Customer Needs

* Max. Lifting height is measured with adjustable screw pads in highest position.
 * Machine shown with optional equipment. Actual product appearance may differ.



Round Screw-up Lifting Pad and Triple Telescope Straight Arm | Strong Carriage and Arm Structure

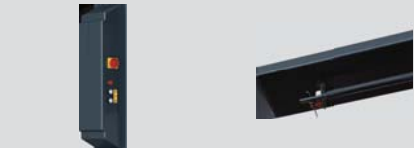

Electrical release | Vehicle Roof Protection Limit Switch



Easier for making both sides work synchronously



EE-C12E

CLEAR FLOOR LIFT

- 6000kg lifting capacity.
- 1900mm lifting height.
- Cylinder straight top device, run more smoothly.
- Clear floor design for easy movement of maintenance equipment under the raised vehicle.
- Durable cylinders in each column carry with anti-surge valves.
- Screw-up lifting pads with clearance height as low as 110mm.

TWO POST LIFT

5000KG | **2000MM** | **Versatile**
 Lifting Capacity | Max. Lifting Height with Standard SUV Adapters | From Smart To Sprinter



EE-6255E



EE-6215E



EE-6255E/6215E

BASE PLATE LIFT/CLEAR FLOOR LIFT

- 5000kg lifting capacity.
- 1900mm lifting height.
- Only 40 seconds raising time with optional quick motor to shorten your service time.
- The four triple stage arms combination make the lift can accommodate wide range of vehicles from Smart to Sprinter, light van.
- Durable cylinders in each column carry with anti-surge valves.
- Screw-up lifting pads with clearance height less than 100mm.
- The arm locks engage and disengage automatically.
- Aluminum motor avoids overheating and ensures long service life.
- Standard door protection pads to prevent possible damage to the door opened without caution.

OVERALL DIMENSION

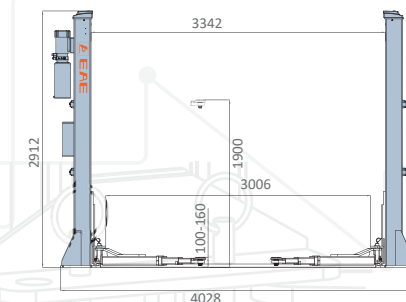

EE-6255E

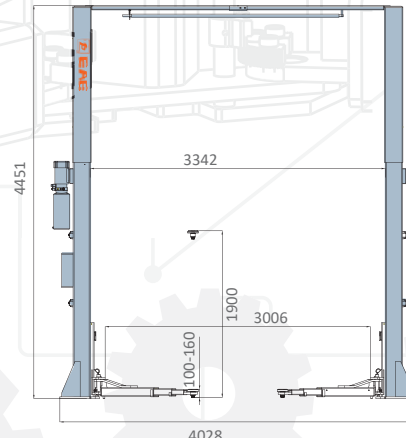
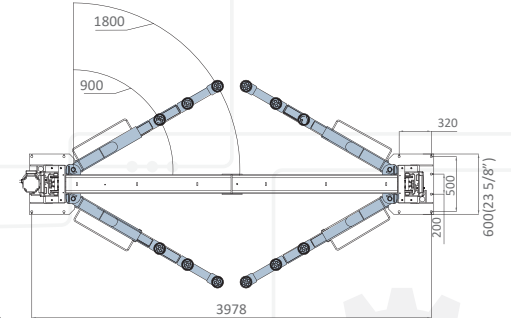

EE-6215E

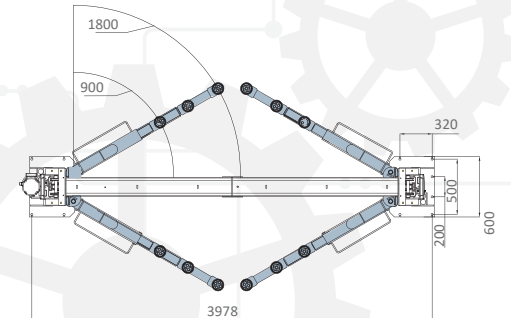

TECHNICAL DATA

MODEL NO	EE-6255E	EE-6215E
Lifting capacity	5000kg	5000kg
Max lifting height	1900mm	1900mm
Drive-through width	3006mm	3006mm
Lifting time	45S-60S	45S-60S
Motor	2.2kW/3.5kW	2.2kW/3.5kW
Rated oil pressure	22MPa	19MPa
Weight	924kg	1060kg
Electricity supply	According To Customer Needs	

* Max. Lifting height is measured with adjustable screw pads in highest position.
 * Machine shown with optional equipment. Actual product appearance may differ.



Arm Lock



Strong Carriage and Arm Structure



Chain(EE-6215E)



5T 100mm Casting Height Adapter



Round Screw-up Lifting Pad and Triple Telescope Straight Arm

4000/5000KG
Lifting Capacity

2070MM
Max. Lifting Height
with Standard SUV Adapters

Asymmetric
30 degree column installation
for wider door opening



Wider Door Opening



EE-6214EKZ/6215EKZ

ASYMMETRIC CLEAR FLOOR LIFT

- 4000kg/5000kg lifting capacity.
- 1970mm lifting height.
- 30 degree of columns installation leaves more space for opening the door.
- Electrical release, simply press Up and Down button to operate the lift.
- Only 45 seconds raising time with optional quick motor to shorten your service time.
- The four triple stage arms combination make the lift can accommodate wide range of vehicles from Smart to Sprinter, light van.
- Baseless design for easy movement of maintenance equipment under the raised vehicle.
- Durable cylinders in each column carry with anti-surge valves.
- Screw-up lifting pads with clearance height less than 100mm.
- The arm locks engage and disengage automatically.
- With vehicle roof protection. The power system switches off when vehicle roof touches the rubber protected overhead bar.
- Aluminum motor avoids overheating and ensures long service life.
- Durable powder coating.
- Standard door protection pads to prevent possible damage to the door open without caution.
- Standard chain protection curtain.
- Pre-fixed hydraulic pressure prevents overloading operation.
- ABS control box with rubber gasket sealing.
- CE certified by SGS UK.

OVERALL DIMENSION

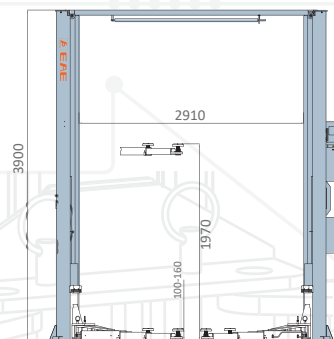

EE-6214EKZ

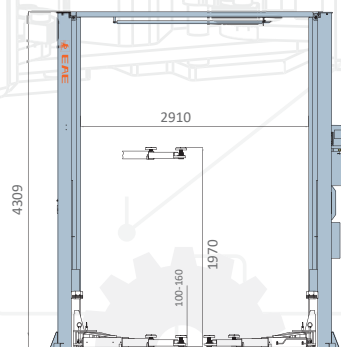
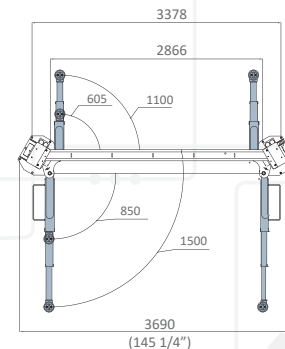

EE-6215EKZ

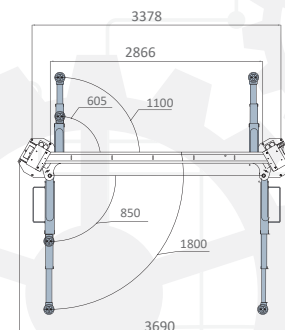

TECHNICAL DATA

MODEL NO.	EE-6214EKZ	EE-6215EKZ
Lifting capacity	4000kg	5000kg
Max lifting height	1970mm	1970mm
Drive-through width	2500mm	2500mm
Lifting time	45S-55S	45S-55S
Motor	2.2kW/3.5kW	2.2kW/3.5kW
Rated oil pressure	18MPa	19MPa
Weight	620kg	800kg
Electricity supply	According To Customer Needs	

* Max. Lifting height is measured with adjustable screw pads in highest position.

* Machine shown with optional equipment. Actual product appearance may differ.



TWO POST LIFT

4200KG
Max. Capacity

APS
Accurate Parking System
Technology By EAE

2000MM
Max. Lifting Height
with Standard SUV Adapters



Accurate Parking System

Accurate Parking System, abbreviated as APS, is a perfect solution that when do chassis maintenance, transmission repair or changing, when you want to lower the vehicle a little bit for more comfortable working condition, but the vehicle has to be raised up high enough for the lift to release the safety locking, which is not time saving and hard to park the vehicle at the accurate height you really want. EAE applied this technology to its new generation two post lift, 62 series, permits you park the vehicle at any height and lower the vehicle directly and accurately.

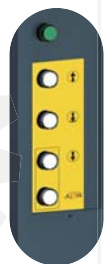

EE-62C



EE-62B



H frame for poor floor

EE-62B/62C

TWO POST LIFT WITH APS TECHNOLOGY

- Base Plate type design for low ceiling workshops and garages.(62B)
- Clear floor design for easy movement of maintenance equipment under the raised vehicle.(62C)
- With APS technology.
- 1900mm lifting height.
- 3500kg/4200kg lifting capacity.
- Durable cylinders in each column carry with anti-surge valves.
- Screw-up lifting pads with clearance height less than 100mm.
- The arm locks engage and disengage automatically.
- The rubber protected overhead bar switches off the power system when vehicle roof touches it.(62C)
- Standard aluminum motor avoids being overheated and ensures long service life.
- Durable powder coating.
- Standard door protection pads to prevent possible damage when the door opened without caution.
- Standard chain protection curtain.
- Pre-fixed hydraulic pressure prevents overloading operation.
- ABS control box with rubber gasket sealing.
- CE certificated by SGS UK.

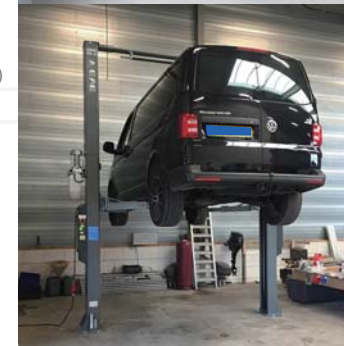

Swing Arm Lock



Strong Carriage and Arm Structure



4x100mm Casting Height Adapter



Chain(EE-62B)



24V Control Box

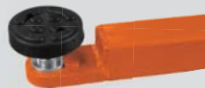

Round Screw-up Lifting Pad

OVERALL DIMENSION

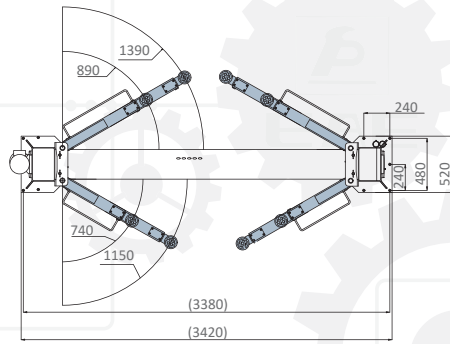
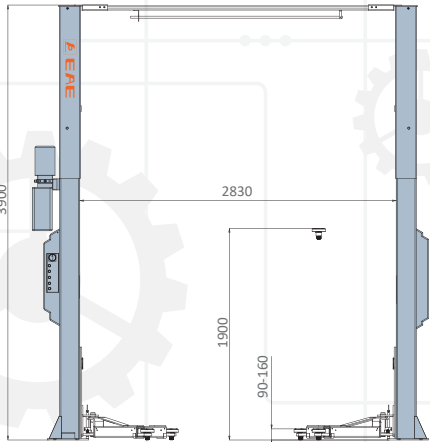
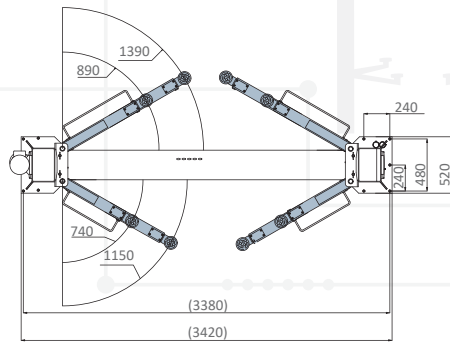
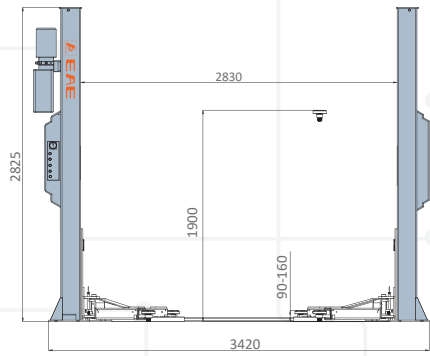

TECHNICAL DATA

MODEL NO.	EE62B-35T-E	EE62B-42T-E	EE62C-35T-E	EE62C-42T-E
Structure Type	Baseplate	Baseplate	Clearfloor	Clearfloor
Locking Release	Down button	Down button	Down button	Down button
Lifting Capacity	3500kg	4200kg	3500kg	4200kg
Max Lifting Height	1900mm	1900mm	1900mm	1900mm
Overall Height	2850mm	2850mm	3900mm	3900mm
Minimum Height	90mm	90mm	90mm	90mm
Overall Width	3420mm	3420mm	3420mm	3420mm
Drive Thru Width	2500mm	2500mm	2500mm	2500mm
Inside Column	2830mm	2830mm	2830mm	2830mm
Two Stage Rear Long Arm	890-1390mm	890-1390mm	890-1390mm	890-1390mm
Two Stage Front ShortArm	740-1150mm	740-1150mm	740-1150mm	740-1150mm
Three Stage Arm	615-1150mm	615-1150mm	615-1150mm	615-1150mm
Lifting Time	455-555	455-555	455-555	455-555
Motor	2.2kW/3.5kW			
Power Supply	Recommend Supply 110/220V/240V/380V/415V(1/3 Phase) According To Customer Needs			

* Max. Lifting height is measured with adjustable screw pads in highest position.
 * Machine shown with optional equipment. Actual product appearance may differ.

TWO POST LIFT



Universal Application



Sprinter(NCV3) With Prism For Rear Pick-up Point



Off-road Vehicles And Commercial Vans



MB Off-road Vehicles GW 460/463,MB100etc



For Vehicle Chassis With _n_Shape Pick-Up Position



For SUV,4x4, Off-road Vehicles.



Commercial Vans at Vehicles Frames-The U-Profile Locks The Vehicle



Sprinter(NCV3) With Positioning Pin For Front Pick-up Point



75mm Casting Height Adapter



4T Slim tray assembly



5T Pallet base assembly



4T Truck bracket



4T Tray holder



4T Truck bracket

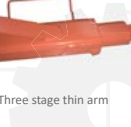

Three stage thin arm



Tool tray

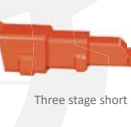

Three stage short arms



Quick Arm



H frame for poor floor

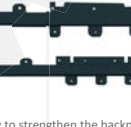

Easy to strengthen the backplane components



Wheel support adapter



Quick Motor

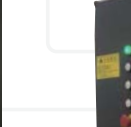

LED light



Air connector

5000KG
Max. Capacity

5780MM
Max. Platform Length

User friendly
Electrical Lock Release (E version)



EE-6435V2.B
(with two optional rolling jacks)



EE-6435V2

FOUR POST LIFT

- Reliable mechanical safety locking system.
- Avoid rapid descending cause by leakage of hydraulic system by applying FLOW-CONTROL technique to hydraulic system.
- Max height switch limits the travel of runways and ensures cylinders work within the stroke.
- Protect against pinching and shearing using alarming buzzer in descending process.
- 24V safety control voltage.
- Reliable electrical release for easy and efficient use.
- Adjustable PD positions can accommodate different types of vehicle.
- Compact quick plug for electrical connection releases installers from too many wires and terminals and make initial installation much more efficient. Save more than 70% time on wire connection.
- Low profile runway is convenient for driving on and off and less demanding on space.

OVERALL DIMENSION

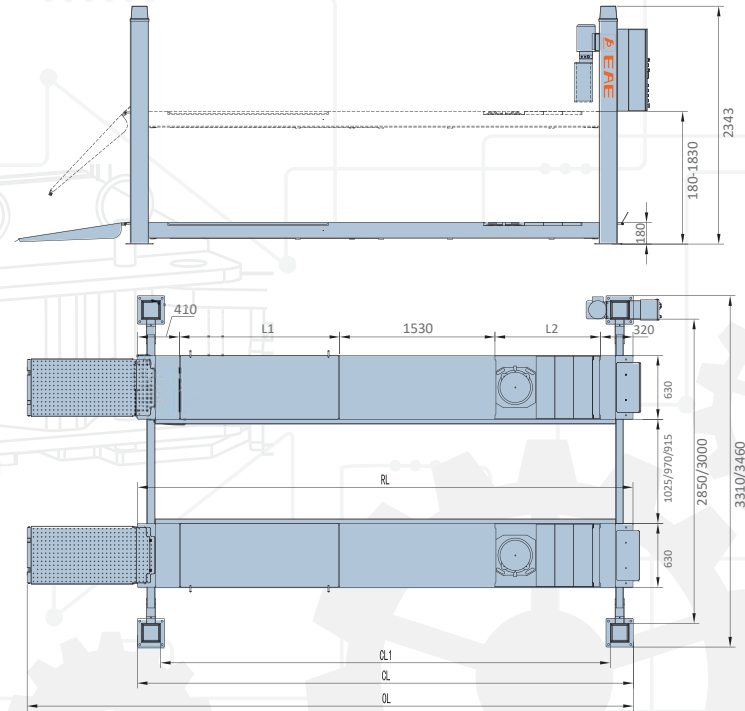

- S Flat platforms
- B Platforms with front recesses and rear slip plates
- B.PD Platforms with front recesses , play detector, and rear slip plates.

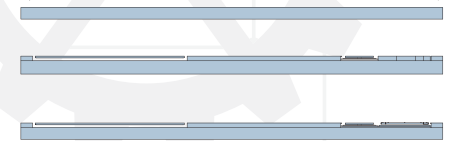

TECHNICAL DATA

Model No.	Lifting capacity	Max lifting height	L1	L2	RL	CL1	CL	OL
6435V2.S.48L	4000kg/5000kg	180-1830	N/A	N/A	4880	4438	4888	5948
6435V2.S.52L					5280	4838	5288	6348
6435V2.S.57L					5780	5338	5788	6848
6435V2.B.48L	4000kg/5000kg	180-1830	1580	1040	4880	4438	4888	5948
6435V2.B.52L			1980		5280	4838	5288	6348
6435V2.B.57L			2480		5780	5338	5788	6848
6435V2.B.PD.48L	4000kg/5000kg	180-1830	1580	1040	4880	4438	4888	5948
6435V2.B.PD.52L			1980		5280	4838	5288	6348
6435V2.B.PD.57L			2480		5780	5338	5788	6848

5000KG
Max. Capacity

3000MM
Between Columns for 3D Aligning

Wheel Free Lift
Standard 4000KG



OVERALL DIMENSION

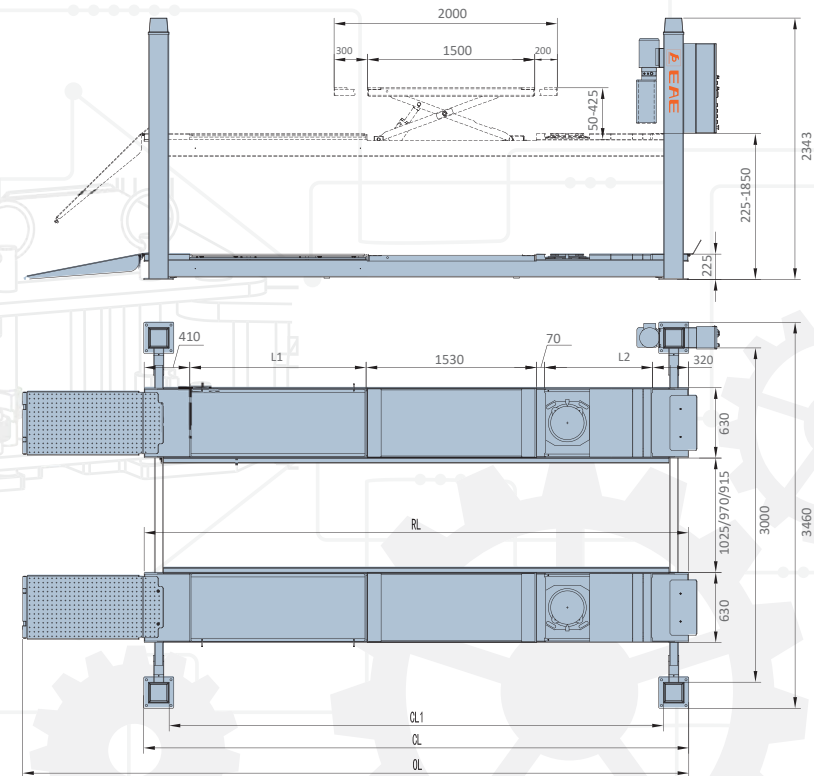

FOUR POST LIFT



EE-6435V2.BWF

FOUR POST LIFT

- 4000kg/5000kg lifting capacity.
- 4000kg capacity wheel free jacks built in runways with extendable ramps for long wheelbase vehicles.
- Long slip plate and adjustable turntable positions accommodate different kinds of wheelbases.
- Electrical release, just press UP and DOWN button to control the lift.
- Wide platforms for easier driving on and off.
- 3000mm distance between two columns compatible to 3D wheel aligner.
- The great planeness of runways is perfect for high accurate wheel aligning.
- Driving-on ramps with polymer rollers.
- Reserved tracks on platforms fit for optional rolling jacks.
- Low profile runway allows the vehicles drive on and off conveniently.
- 24V safe control system.
- Solid and robust cable pulleys.
- Self-lubricated bushing and bearing.
- Platforms non-synchronization alarming system.
- Safety device works immediately in case a cable slacks or fails.
- Alarm buzzer for safe descending.
- Aluminum motor with fan on top to avoid overheating caused by long time working.

TECHNICAL DATA

Model No.	Lifting capacity	Max lifting height	L1	L2	RL	CL1	CL	OL
6435V2.BWF.48L	4000kg/5000kg	225-1850	1580	970	4880	4438	4888	5970
6435V2.BWF.52L			1980		5280	4838	5288	6370
6435V2.BWF.57L	5000kg		2280	1170	5780	5338	5788	6870



Motor Housing



Slip Plate

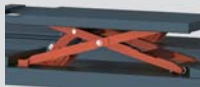

Wheel Free Jack



Oil Hose Protection



Solid and Robust Cable Pulleys

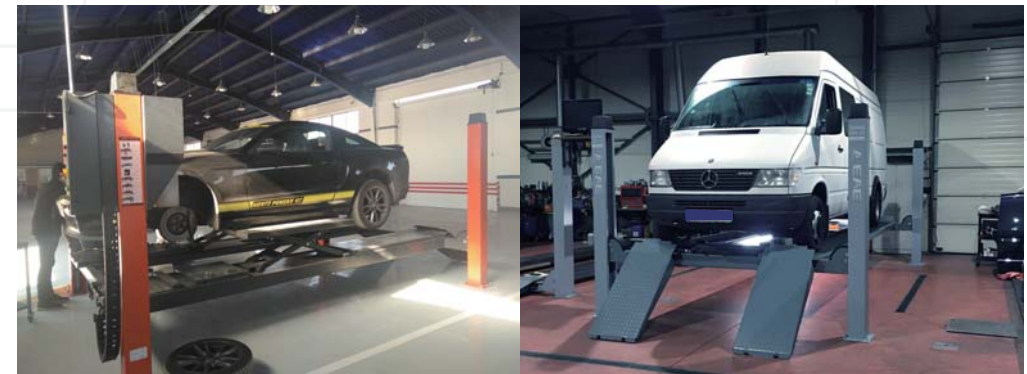

4000KG
Lifting Capacity

1970MM
Lifting Height

4900MM
Longer Runways



OVERALL DIMENSION

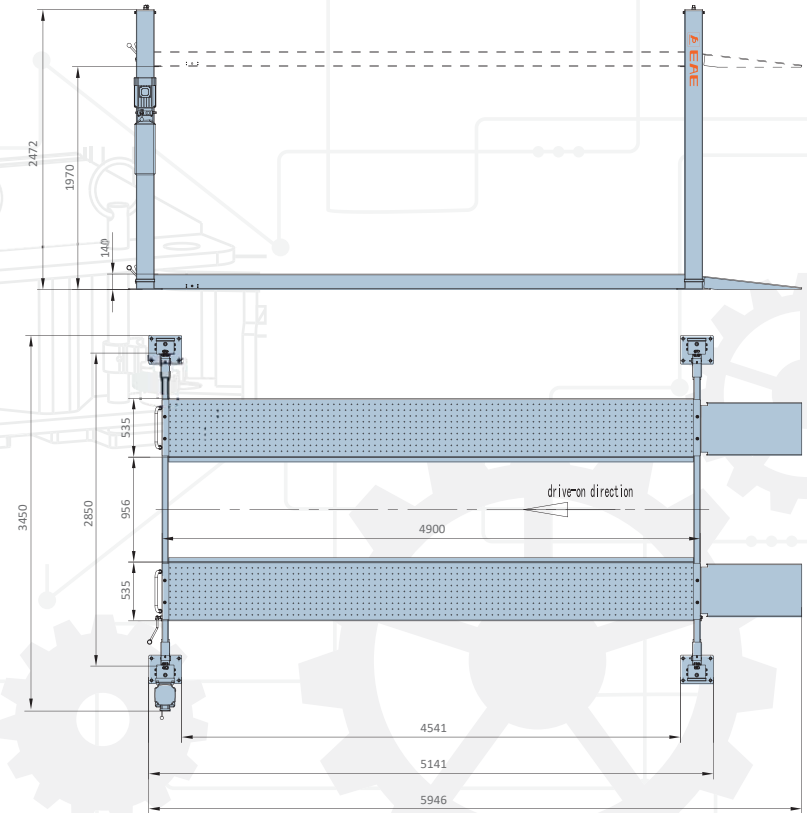

FOUR POST LIFT

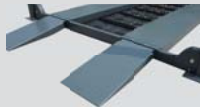

Drive-On Ramp



Standard Oil Drip Pan



EE-6445P

PARKING LIFT

- 4000kg lifting weight, 1970mm lifting height, 4900mm runway length can meet your various parking needs for most of the passenger cars, SUVs or pickup trucks.
- Min. 140mm low profile runway which is essential for parking low chassis sports car.
- Simple but reliable design. User friendly, easy on-site installation and less demanding on foundation.
- Standard oil drip pan and jack tray.
- Optional mobile kits for easier removal and installation.
- Optional aluminum alloy decking make the parking area as a whole. Small vehicles like motorcycle, ATV, lawn mower can park on it.
- One side release for safety locks, easy for descent operation.
- Self-lubricating pulleys and pre-tensioned wire rope for extended service life.
- Mechanical locks automatically engaged into position in ascending process.
- Out of level protection, safe and reliable.

TECHNICAL DATA

MODEL NO.	EE-6445P
Lifting capacity	4,000kg
Max lifting height	1,970mm
Min height	140mm
Post height	2472mm
Into the car width	2850mm
Weight	1150kg
Lifting time	70S
Motor	2.2kW
Height requirements	≥3800mm
Electricity supply	According To Customer Needs

* Machine shown with optional equipment. Actual product appearance may differ.



Safety Ratchet

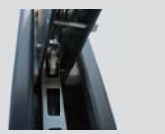

Mechanized Safety Locking Unit



Release Handle And Reset Hand holder

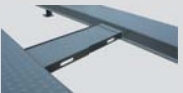

Standard Tool Tra



Cylinder Support



Double Sheave Pulley

4000KG
Lifting Capacity

1970MM
Lifting Height

4900MM
Longer Runways



OVERALL DIMENSION

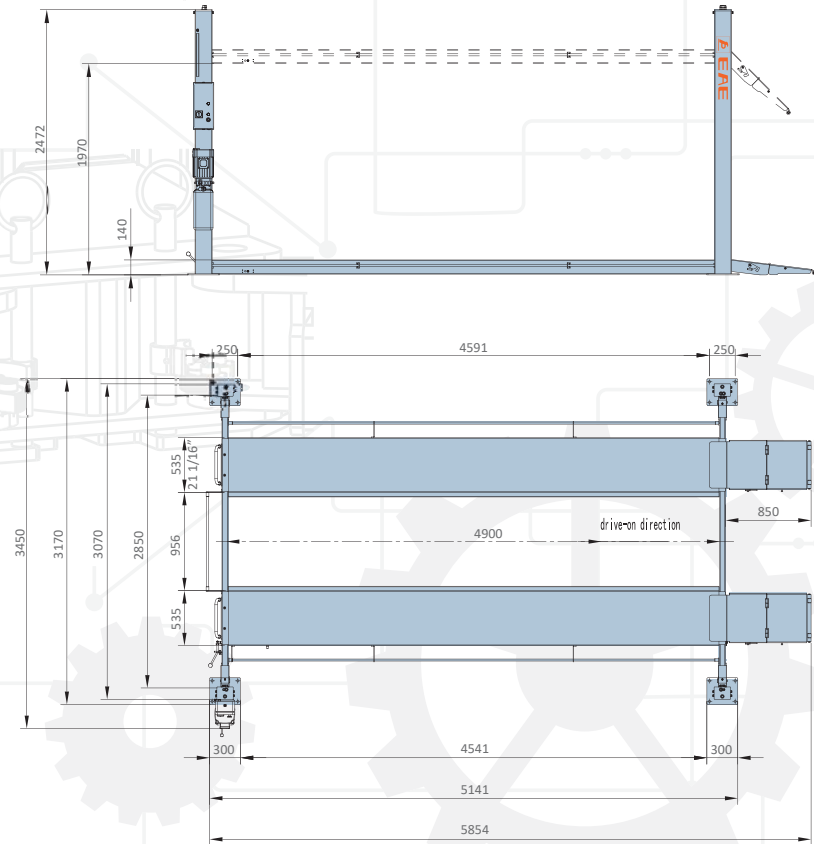

FOUR POST LIFT



EE-4S

FOUR POST LIFT

- 140mm super low initial drive-on height which is crucial to sports cars with low wheelbase.
- Single point operation with manual or pneumatic release for the mechanical safety locking unit. Easy and friendly to operate.
- With reliable steel cable rupture protection.
- Foldable drive-on ramps, space saving and prevent the lifted vehicle from rolling off.
- Compatible with optional movable rolling jacks.
- Powder coated finish improves durability and paint life.

TECHNICAL DATA

MODEL NO.	EE-4S
Lifting capacity	4,000kg
Max lifting height	1,970mm
Min height	140mm
Post height	2472mm
Into the car width	2850mm
Weight	1250kg
Lifting time	70S
Motor	2.2kW
Electricity supply	According To Customer Needs

* Machine shown with optional equipment. Actual product appearance may differ.



Protection Cover



Foldable drive-on ramp



Safety Ratchet



Mechanized Safety Locking Unit



Release Handle And Reset Hand holder



Air regulator



Cylinder Support



Double Sheave Pulley

6000kg | **5424mm** | **All Versions**
Lifting Capacity | Long Platform | S, B, BWF Platforms



EE-HX6BWF

OVERALL DIMENSION

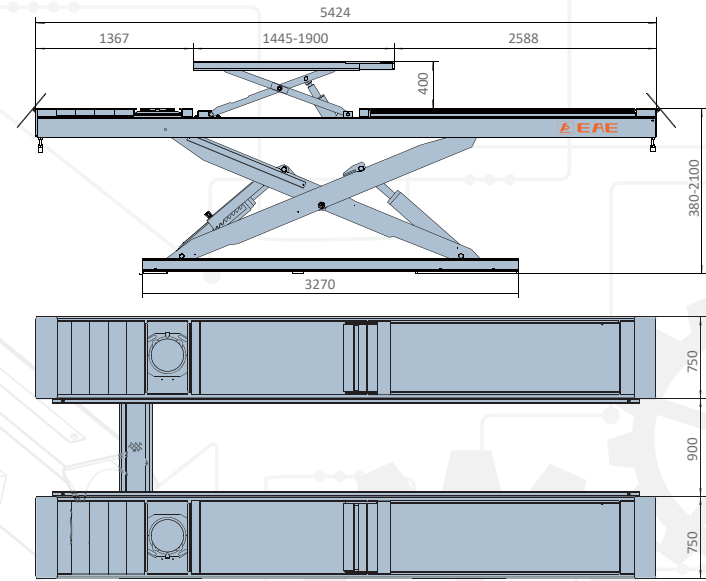

- S Flat platforms
- B Platforms with front recesses and rear slip plates
- BWF Platforms with front recesses, rear slip plates, and wheel free lifts

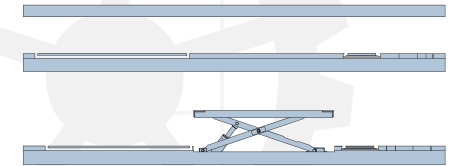

SCISSOR LIFT

TECHNICAL DATA

MODEL NO.	EE-HX6
Lifting capacity	6000kg
Max lifting height	2100mm
Min height	380mm
Lifting time	55s
Motor	2.2kWx2
Air supply	6-8bar
Platform width	750mm
Weight	4500kg
Electricity supply	According To Customer Needs

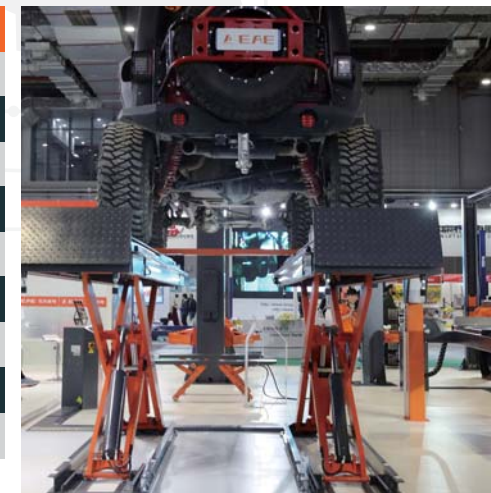

EE-HX6
LONG PLATFORM SCISSOR LIFT

- 6000kg lifting capacity.
- Electrical levelling.
- Infrared synchronization protection system.
- The great planeness of runways is perfect for high accuracy wheel aligning.
- Long slip plate and adjustable turntable positions accommodate different kinds of wheelbases.
- Pneumatic released safety locking system.
- 24V safe control system.
- Self-lubricated bushing and bearing.
- Safety descent alarming buzzer.
- Aluminum motor with fan on top to avoid overheating caused by long time working.
- It has been proved by dynamic test with 115% of rated capacity and static test with 150% capacity.

Long slip plate and adjustable turntable positions accommodate different size of wheelbases.

* Machine shown with optional equipment. Actual product appearance may differ.

4000KG | **180MM** | **Surface Installation**
 Lifting Capacity | Drive-on Height | No More Concrete Work Ramps Included



EE-6604V2.BWF

OVERALL DIMENSION

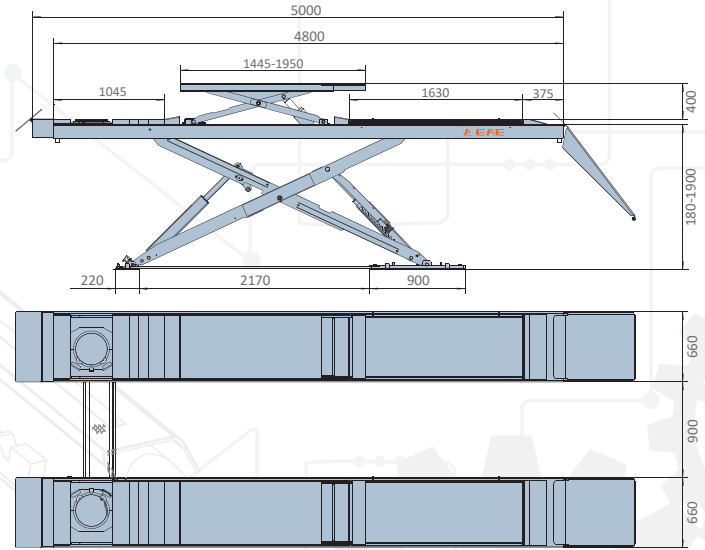

- S Flat platforms
- B Platforms with front recesses and rear slip plates
- B.PD Platforms with front recesses, play detector, and rear slip plates.
- BWF Platforms with front recesses, rear slip plates, and wheel free lifts

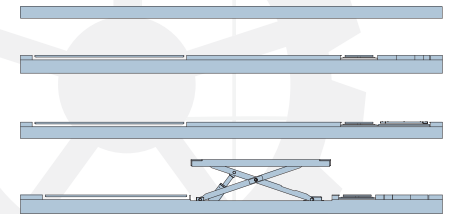

TECHNICAL DATA

MODEL NO.	EE-6604V2
Lifting capacity	4000kg
Max lifting height	1900mm
Min height	180mm
Lifting time	55S
Motor	3.5kW/3ph, 2.2kW/1ph
Air supply	6-8bar
Platform width	660mm
Weight	2400kg
Electricity supply	According To Customer Needs

* Machine shown with optional equipment. Actual product appearance may differ.



EE-6604V2

LOW PROFILE SCISSOR LIFT

- 4000kg lifting capacity.
- Above-ground installation.
- Low profile runway needs less space.
- Electrical levelling.
- Infrared synchronization protection system.
- The great planeness of runways is perfect for high accuracy wheel aligning.
- Long slip plate and adjustable turntable positions accommodate different sizes of wheelbases.
- Reserved tracks on platforms fit for optional rolling jacks.
- Pneumatic safety locking system
- 24V safe control system.
- Self-lubricated bushing and bearing.
- Safety descent alarming buzzer.
- Aluminum motor with fan on top to avoid overheating caused by long time working.



Turntable (Optional)



Rear side slip



Anti-abrasion Slider



Drive-on Ramp



Pneumatic Release Mechanical Lock



Wheel Free Lift (Optional)



SCISSOR LIFT

5000KG | **5100MM** | **ALS**
 Max. Capacity | Max. Platform Length | Automatic Levelling System(Optional)



OVERALL DIMENSION

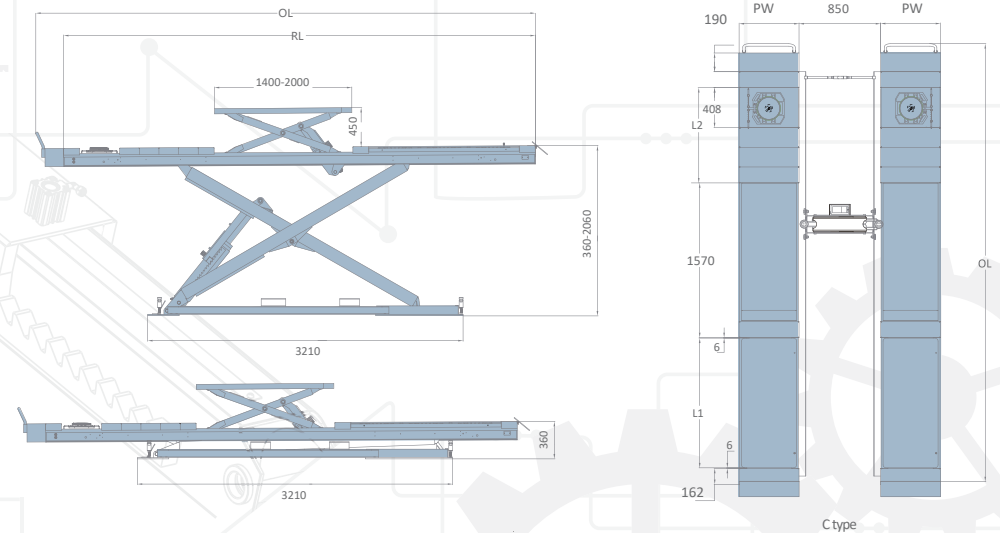

- S Flat platforms
- B Platforms with front recesses and rear slip plates
- BWF Platforms with front recesses rear slip plates, and wheel free lifts
- BWF.PD Platforms with front recesses, rear slip plates, play detector and wheel free lifts

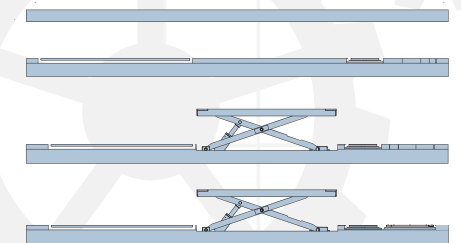

Wheel Free Lift



Pneumatic Release System

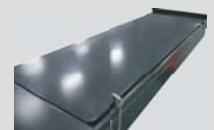

Slip Plate



Mechanical Lock



EE-6603

ALIGNMENT SCISSOR LIFT

- 4200kg/5000kg lifting capacity.
- Electrical or manual levelling.
- Infrared synchronization protection system.
- In-ground installation or above-ground installation with optional drive-on ramps.
- Long slip plate and adjustable turntable positions accommodate different sizes of wheelbases.
- Pneumatic safety locking system.
- The great planeness of runways is perfect for high accuracy wheel aligning.
- Driving-on ramps with polymer rollers.
- Reserved tracks on platforms fit for optional rolling jacks.(C Type)
- 24V safe control system.
- Self-lubricated bushing and bearing.
- Safety descent alarming buzzer.
- Aluminum motor with fan on top to avoid overheating caused by long time working.

TECHNICAL DATA

Model No.	Lifting capacity	PW	RL	OL	L1	L2
EE-6603.S.42L(C)	4200kg	610	4200	4442	N/A	N/A
EE-6603.S.48L(C)	4200kg/5000kg	610	4800	5042	N/A	N/A
EE-6603.S.51L(C)	4200kg/5000kg	610	5100	5342	N/A	N/A
EE-6603.B.42L(C)	4200kg	610	4200	4442	1320	970
EE-6603.B.48L(C)	4200kg/5000kg	610	4800	5042	1520	1370
EE-6603.B.51L(C)	4200kg/5000kg	610	5100	5342	1520	1570
EE-6603.BWF.42L(C)	4200kg	610	4200	4442	1320	970
EE-6603.BWF.48L(C)	4200kg/5000kg	610	4800	5042	1520	1370
EE-6603.BWF.51L(C)	4200kg/5000kg	610	5100	5342	1520	1570
EE-6603.BWF.PD.48L(C)	5000kg	610	4800	5042	1520	1370
EE-6603.BWF.PD.51L(C)	5000kg	610	5100	5342	1520	1570

* Machine shown with optional equipment. Actual product appearance may differ.

3500KG
Lifting Capacity

140MM
Drive-on Height

Add-On
Wheel Alignment runway kit (B type)



EE-LX35B
(with optional rolling jacks)

OVERALL DIMENSION

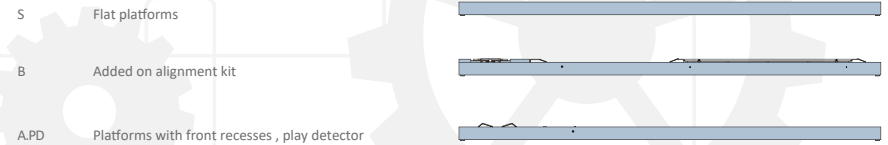
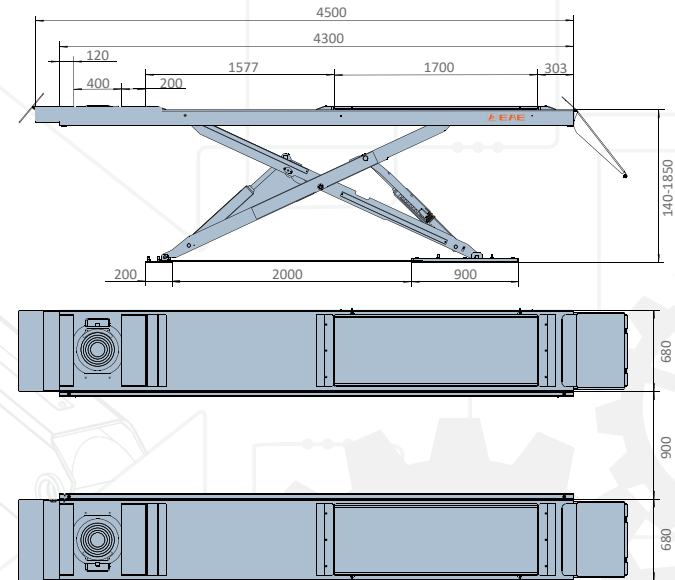

Compatible to auxiliary rolling jack for wheel free service



Turntable (Optional)

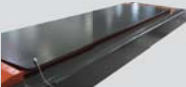

Add-on alignment kit



Mechanical Safety Lock



EE-LX35

LOW PROFILE SCISSOR LIFT

- Six-Cylinder mechanical structure. Reliable mechanical locking system protects against rupture of hydraulic circuit and ensure better mechanical balance when it is engaged.
- Avoid rapid descending cause by leakage of hydraulic system by applying FLOW-CONTROL technique to hydraulic system.
- Max height switch limits the travel of runways and ensures cylinders work within the stroke.
- Protect against pinching and shearing using alarming buzzer in descending process.
- 24V safety control voltage.
- Low profile runway design is less demanding on space and suitable for surface installation in basement and other place where it is forbidden to dig pit.
- Flat and smooth runway (type S) is better for quick body checking service.
- Aluminum motor avoids overheating.
- Compatible to auxiliary rolling jack for wheel free service.
- Modular design meets various practical needs. It is possible to extend S runway to B runway with extra accessories.

TECHNICAL DATA

MODEL NO.	EE-LX35
Lifting capacity	3500kg
Max lifting height	1850mm
Min height	140mm
Motor	2.2kW/1ph, 3.5kW/3ph(S/B), 2.2kW+3.5kW (A.PD)
Platform width	680mm
Air supply	6-8bar
Lifting time	55S
Weight	2200kg
Electricity supply	According To Customer Needs

* Machine shown with optional equipment. Actual product appearance may differ.



**3000KG
EE-CJ**



**3000KG
EE-SCJ**

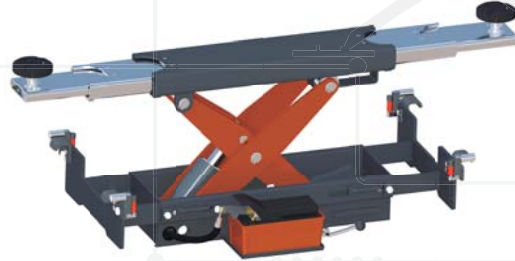

OVERALL DIMENSION

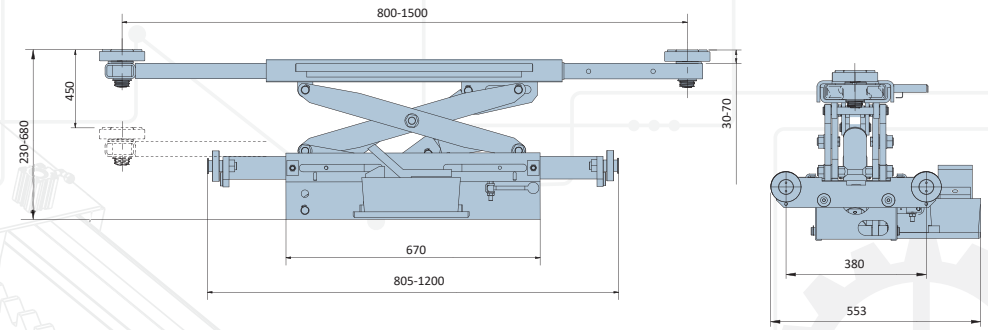

EE-CJ

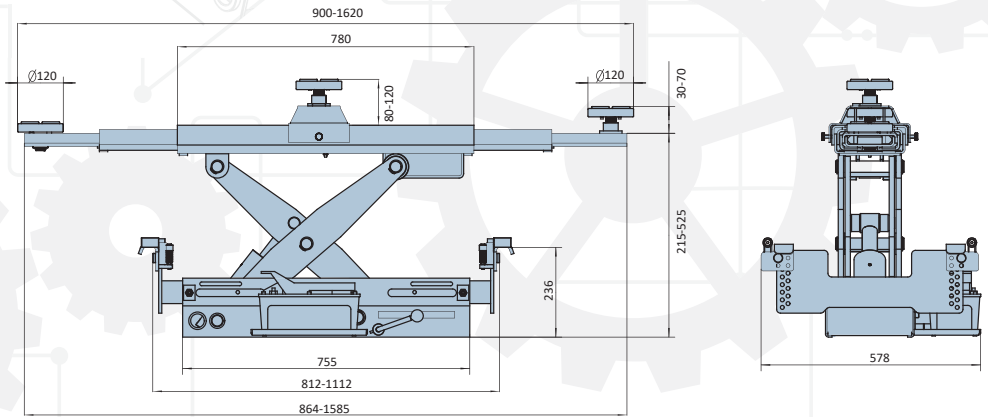

EE-SCJ

MAIN FEATURES

- Durable and compact scissor carrying structure
- Adjustable width between support wheels to fit different widths between runways
- Holder-pads extension for various wheelbases
- With manual release mechanical safety locking unit
- Steel-made driving rolls with ball-bearings move easily and smoothly on the track
- Manual or pneumatic drive

TECHNICAL DATA

Model NO.	EE-CJ		EE-SCJ	
Type	Manual Pump	Air Pump	Manual Pump	Air Pump
Lifting capacity	3000kg	3000kg	3000kg	3000kg
Max stroke	450mm	450mm	310mm	310mm
Initial height	230mm	230mm	245mm	245mm
Platform width	805-1200mm	805-1200mm	820-1120mm	820-1120mm
Width between adapters	800-1500mm	800-1500mm	785-1500mm	785-1700mm
Support beam	Two stage	Two stage	Three stage	Three stage
Air supply	/	6-8bar	/	6-8bar
Rated oil pressure	24MPa	24MPa	24MPa	24MPa
Weight	160kg	160kg	170kg	170kg

* Technical data and composition presented in this catalogue may vary. Pictures reproduced are only indicative.





4000KG/5000KG
EE-6435V2.B.PD



4200KG/5000KG
EE-6603B.PD



4000KG
EE-6604V2.B.PD

*Detailed specifications for the MOT & ATL lifts, please refer to LONG PLATFORM SCISSOR LIFT SERIES and FOUR POST LIFT SERIES.

Play Detector

Features of Automobile Suspension Steering System Clearance Tester

It is convenient to check parts fit clearance of automobile suspension steering system. Make sure the front or rear wheels on top of two test boards. Manipulate the two test boards by the switches on the handheld remote control, or the PD remote-control unit, move left and right or rotate. It can easily figure out the clearance of pull rod, ball head, steering arms, wheel bearing, etc.

High quality steel, high intensity body, good brand hydraulic spare parts, stable and reliable performance. The clearance tester adopts hydraulic drive. Deck plate can move smoothly under the action of hydraulic pressure, with great displacement force. Lighting and control switch on the handheld remote control, easy to control and observe.

This product is especially suitable for monitoring station, routine inspection station in car dealerships, repair shops, etc.



Move Route of Play Detector

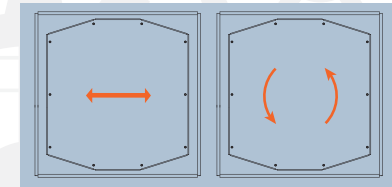

PD

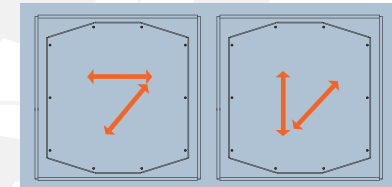

PD6

TECHNICAL DATA

Model NO.	EE-PD	EE-PD6
Maximum axle weight	3000kg	3000kg
Maximum wheel weight	1500kg	1500kg
Maximum displacement	±40mm	50mm
Maximum sliding force	>3300daN	>3300daN
Maximum plate rotation	±14°	/
Dimensions platform (LxW)	630x630mm	725x630mm
Two Plates Inner Width x Outer Width	710x1970mm	925x2375mm
Working Mode	Hydraulic Drive	Hydraulic Drive
Motor	2.2kW	2.2kW
Electrical supply	According To Customer Needs	According To Customer Needs

* Machine shown with optional equipment. Actual product appearance may differ.



4000KG Lifting Capacity | **130MM** Drive-on Height | **1930MM** Max. Lifting Height



Optional ramp for lower profile

OVERALL DIMENSION

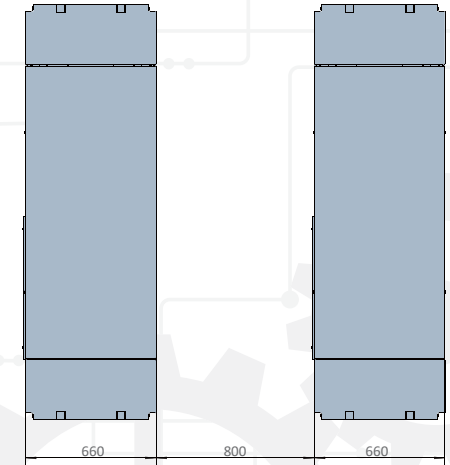
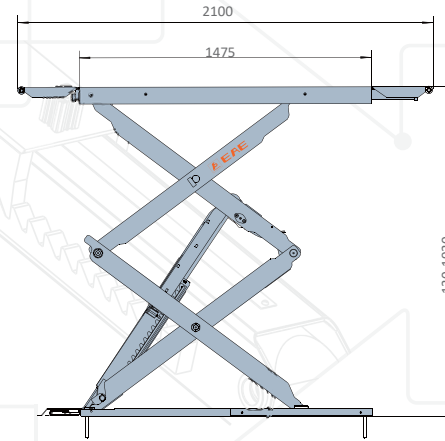

TECHNICAL DATA

MODEL NO.	EE-65A.40T
Lifting capacity	4000kg
Max lifting height	1930mm
Min height	130mm
Lifting time	60S
Motor	2.2kW
Air supply	6-8bar
Platform width	660mm
Weight	1000kg
Electricity supply	According To Customer Needs

* Machine shown with optional equipment. Actual product appearance may differ.

EE-65A.40T

FULL RISE SCISSOR LIFT

- 4000kg lifting capacity.
- Above-ground or recessed installation.
- 130mm initial height.
- Four cylinder design.
- Pneumatic released safety locking system.
- Drive-on ramps lock into position as platform extensions.
- Steady raising and lowering, no noise when lowered to ground.
- Durable cylinders with anti-surge valves.
- 24V safe control system.
- Height limit switch.
- Powder coated finish.
- Self-lubricated bushing and bearing.
- Aluminum motor with fan on top to avoid overheating caused by long time working.
- It has been proofed by dynamic test with 115% of rated capacity and static test with 150% capacity.



Anti-abrasion Slider



Height Limit Switch



Mechanical Safety Lock



24v Safe Control System



Start-Up Plate



Four Cylinder Design



In-ground installation.

SCISSOR LIFT

110MM Drive-on Height | Curved Type Starting up plate | ALS Automatic Levelling System(Optional)



OVERALL DIMENSION

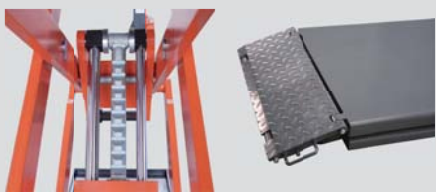
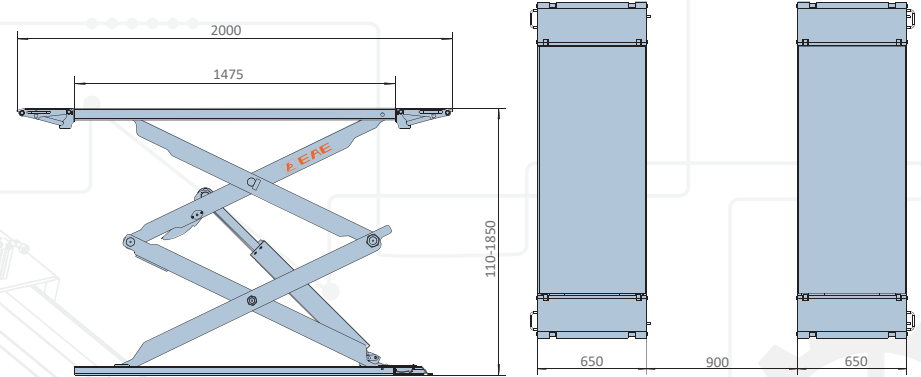

Mechanical Safety Lock



Drive-on Ramp & Platform Extension



EE-6501V2

FULL RISE SCISSOR LIFT

- 3000kg lifting capacity.
- Above-ground or recessed installation.
- 110mm initial height.
- Infrared synchronization protection system.
- Four cylinder design
- Pneumatic safety locking system
- Drive-on ramps lock into position as platform extensions.
- Steady raising and lowering, no noise when lowered to ground.
- Durable cylinders with anti-surge valves
- 24V safe control system.
- Height limit switch
- Powder coated finish
- Self-lubricated bushing and bearing.
- Aluminum motor with fan on top to avoid overheating caused by long time working.

TECHNICAL DATA

MODEL NO.	EE-6501V2
Lifting capacity	3000kg
Max lifting height	1850mm
Min height	110mm
Lifting time	50S-60S
Motor	2.2kW/3.5kW
Air supply	6-8bar
Platform width	650mm
Weight	900kg
Electricity supply	According To Customer Needs

* Machine shown with optional equipment. Actual product appearance may differ.

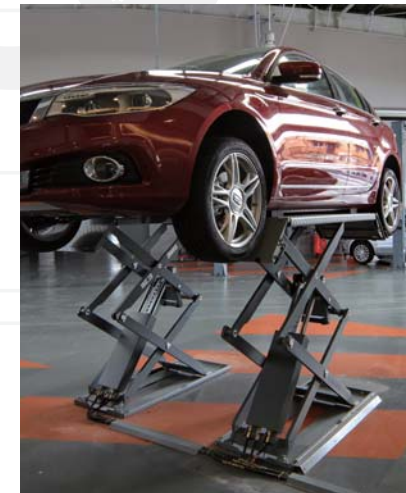

3500KG
Lifting Capacity

Extendable Platform
One Side or Double Sides

ALS
Automatic Levelling System(Optional)



OVERALL DIMENSION

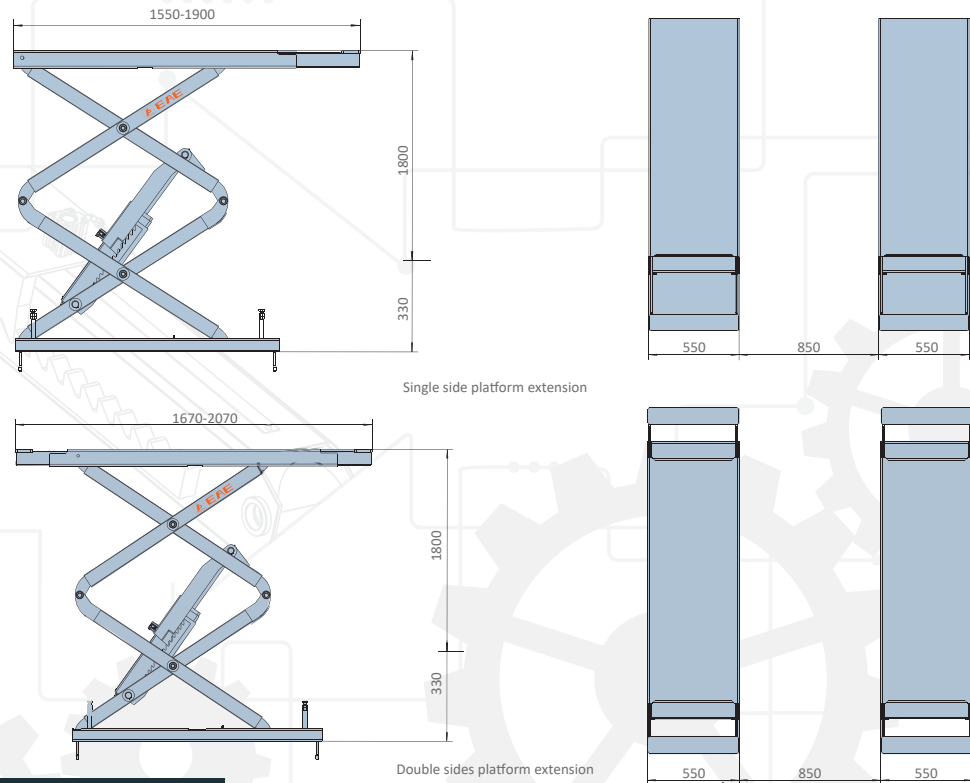

TECHNICAL DATA

MODEL NO.	EE-6503V2
Lifting capacity	3500kg
Max lifting height	2130mm
Min height	330mm
Lifting time	50S-60S
Motor	2.2kW/3.5kW
Air supply	6-8bar
Platform width	550mm
Weight	800kg
Electricity supply	According To Customer Needs

EE-6503V2

FULL RISE SCISSOR LIFT

- 3500kg lifting capacity.
- Recessed installation.
- Infrared synchronization protection system.
- Pneumatic released safety locking system.
- Platforms can be extended for long vehicles.
- Durable cylinders with anti-surge valves.
- 24V safe control system.
- Height limit switch.
- Safety descent alarming buzzer.
- Powder coated finish.
- Self-lubricated bushing and bearing.
- Aluminum motor with fan on top to avoid overheating caused by long time working.



Cylinder Support



High Quality Ball Valve



Pneumatic Release Mechanical Lock



24v Safe Control System

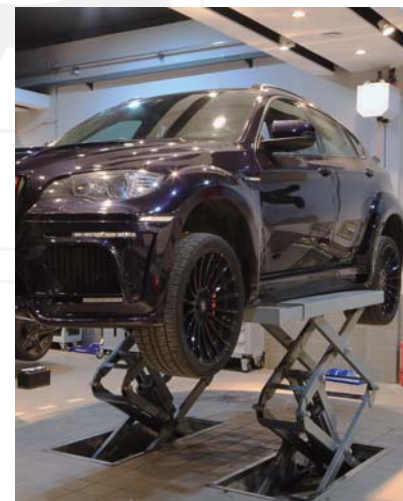

* Machine shown with optional equipment. Actual product appearance may differ.

3500KG | **110MM** | **Starting-Up Plate**
 Lifting Capacity | Drive-on Height | for Easy Raising at Low Point



OVERALL DIMENSION

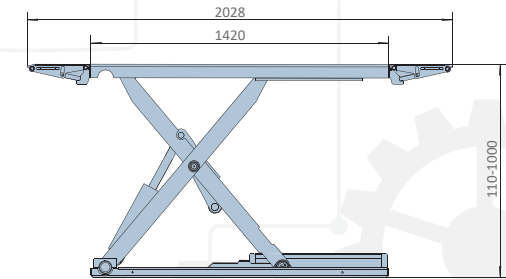
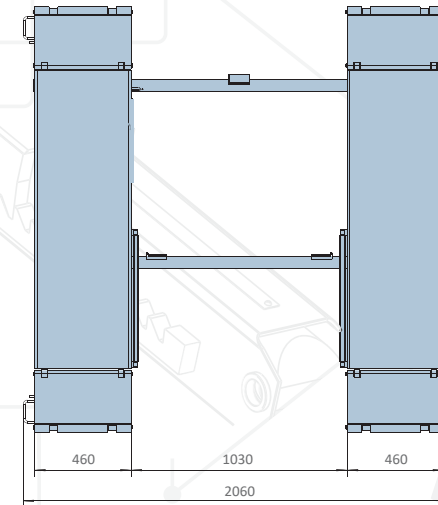

EE-MR35

MID RISE SCISSOR LIFT

- 3500kg lifting capacity.
- Ideal for tire service and narrow bays.
- Mobile or fixed mount design.
- Pneumatic released or electrical released can be available.
- Durable cylinders with anti-surge valves.
- 24V safe control system.
- Height limit switch.
- Powder coated finish.
- Self-lubricated bushing and bearing.
- The safeguard against one end tilting allows car to drive from either side.
- Drive up ramps lock into position as platform extension for long vehicles.
- Optional mobile kit makes the lift move in your garage very easily.
- Aluminum motor with fan on top to avoid overheating caused by long time working.

TECHNICAL DATA

MODEL NO.	EE-MR35
Lifting capacity	3500kg
Max lifting height	1000mm
Min height	110mm
Lifting time	30S
Motor	2.2kW
Air supply	6-8bar
Platform width	460mm
Weight	580kg
Electricity supply	According To Customer Needs

* Machine shown with optional equipment. Actual product appearance may differ.



Low Voltage & Movable Control Unit

Start-Up plate

The safeguard against one end tilting allows car to drive from either side.

Drive-on ramps lock into position as platform extension for long vehicles.

Mechanical Safety Lock

Optional mobile kit makes the lift move in your garage very easily.



SCISSOR LIFT

3000KG
Lifting Capacity

105MM
Drive-on Height

Double Safety
Hydraulic and Mechanical



OVERALL DIMENSION

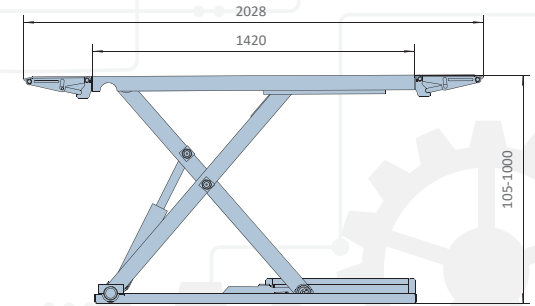
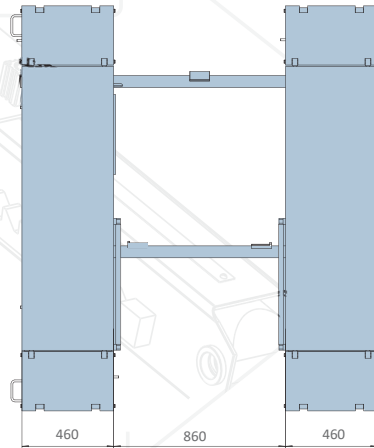

EE-MR30

MID RISE SCISSOR LIFT

- Ideal for tire service and narrow bays.
- Mobile or fixed mount design.
- 3000kg lifting capacity.
- Pneumatic released safety locking system.
- Durable cylinders with anti-surge valves.
- 24V safe control system.
- Height limit switch.
- Powder coated finish.
- Self-lubricated bushing and bearing.
- The safeguard against one end tilting allows car to drive from either side.
- Drive up ramps lock into position as platform extension for longer vehicles.
- Optional mobile kit makes the lift move in your garage very easily.
- Aluminum motor with fan on top to avoid overheating caused by long time working.

TECHNICAL DATA

MODEL NO.	EE-MR30
Lifting capacity	3000kg
Max lifting height	1000mm
Min height	105mm
Lifting time	30S
Motor	2.2kW
Air supply	6-8bar
Platform width	460mm
Weight	500kg
Electricity supply	According To Customer Needs

* Machine shown with optional equipment. Actual product appearance may differ.



3000KG
Lifting Capacity

Movable
Easy to move

Double Safety
Hydraulic and Mechanical



OVERALL DIMENSION

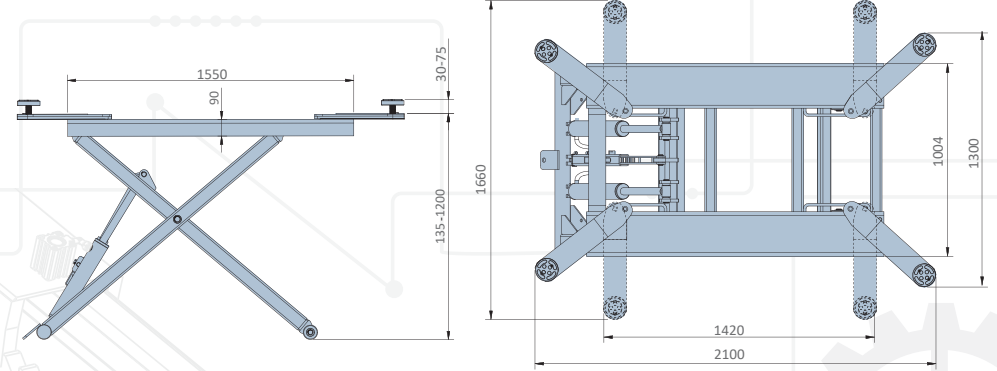

EE-TS6600

MID RISE SCISSOR LIFT

- Manual safety lock release.
- Easy to move, Mobile design.
- Dual cylinder structure, ensure stable raising and lowering.
- Ideal for tire service and narrow bays.
- Powder coated finish.
- It has been proofed by dynamic test with 115% of rated capacity and static test with 150% capacity.



TECHNICAL DATA

MODEL NO.	EE-TS6600
Lifting capacity	3000kg
Max lifting height	1200mm
Min height	135mm
Lifting time	45S
Motor	2.2kW
Weight	450kg
Electricity supply	According To Customer Needs

* Machine shown with optional equipment. Actual product appearance may differ.



Straight Arm



Mechanical Safety Lock



Dual Cylinder Structure



Movable Control Unit



Low Position

1000KG
Lifting Capacity

Pneumatic Driven
Hydraulic Pump

Movable
Space Saving



OVERALL DIMENSION

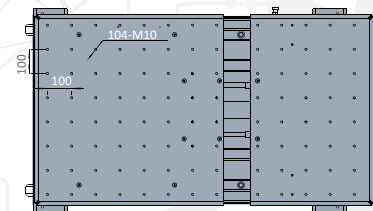
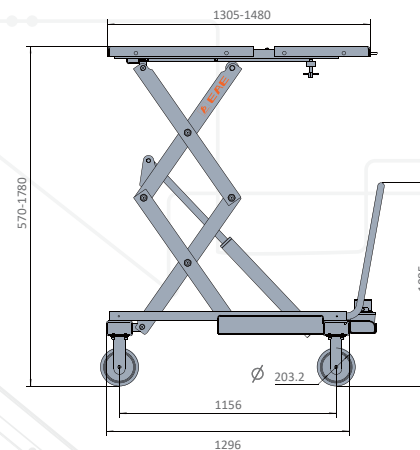

The working table can be extended to 1480mm in length for more applications.



Control and power by foot activated pneumatic driven hydraulic pump.



Four heavy-duty and abrasion-resisting casters can steer and move easily and brake effectively.

EE-MS10

MOBILE LIFTING TABLE

- Designed for dismantling and fixing battery packs of electric vehicles as well as engine, gearbox, drive axle, fuel tank, suspension, bracket and chassis components of traditional vehicles.
- Control and power by foot activated pneumatic driven hydraulic pump.
- The working table can be tilted by adjusting two independent screws attached with T shape handle.
- The working table can be extended to 1480mm in length for more applications.
- Reserved holes (100mmx100mm) on the working table for positioning and fixing components with specialized fixtures.
- Four heavy-duty and abrasion-resisting casters can steer and move easily and brake effectively.
- Optional non-slip rubber pad to increase friction and avoid clashing with the battery packs.
- Hydraulic cylinder and seal rings with high quality. Overload dynamic test under 120% of the rated capacity.
- Larger base frame ensures better stability and reliability.
- Reserved holes at both sides of the working table for fixing loads with proper straps.
- Power-coating surface ensure long time use without peeling off.

TECHNICAL DATA

MODEL NO.	EE-MS10
Rated Capacity	1000kg
Full rise height	1780mm
Initial height	570mm
Air supply pressure	6-8bar
Full rise time	110S
Extended	170mm
Platform Length	1305mm-1480mm
Platform Width	790mm

* Machine shown with optional equipment. Actual product appearance may differ.



SCISSOR LIFT

1200KG
Lifting Capacity

Wireless Control
Convenient and Reliable

Movable
Space Saving



OVERALL DIMENSION

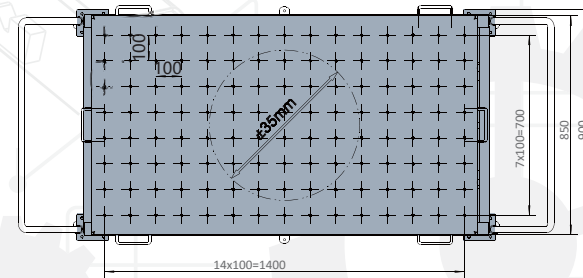
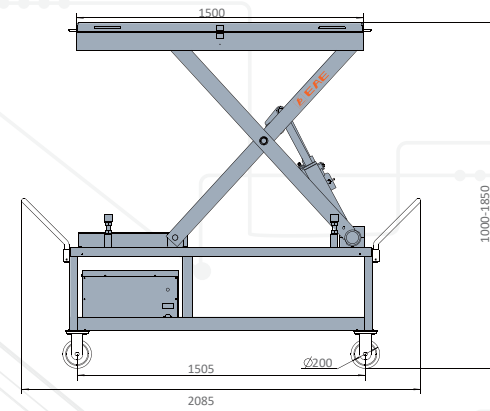

EE-MS12

MOBILE LIFTING TABLE

- This mobile lifting table is designed for dismantling and fixing batteries of electric vehicles as well as engine, gearbox, drive axle, fuel tank, suspension, bracket and chassis components of traditional vehicles.
- The mobile and compact structure make it easily enter into the service space.
- With a maximum lifting capacity of 1200kg and relatively large working table dimensioned 1500x850mm.
- Reserved holes (100mmx100mm) on the working table for positioning and fixing components with specialized fixtures.
- Suspended working table which is able to move freely within a radius of 35mm.
- Hydraulic driven with mechanical safety locking protection. Stable, safe and efficient.
- Wireless control and DC12V powering system. Convenient and reliable.
- Four heavy-duty and abrasion-resisting casters can steer and move easily and brake effectively.
- Powered by independent batteries. No need to connect with external power supply.
- Both sides fixed with handles for easier pushing and pulling the suspended table to whatever direction.
- Storage area above the base plate ensures quick access to tools or spare parts and reduces the possibility of losses.



Suspended working table which is able to move freely within a radius of 35mm.
Reserved holes (100mmx100mm) on the working table for positioning and fixing components with specialized fixtures.



Mechanical lock (released)



Mechanical lock (engaged)



Four heavy-duty and abrasion-resisting casters can steer and move easily and brake effectively.



Hand held remote control

TECHNICAL DATA

MODEL NO.	EE-MS12
Lifting capacity	1200kg
Max lifting height	1850mm
Min height	1000mm
Total length	1500mm
Total width	850mm
Motor Power	1.6kW
Power requirements	DC12V
Lifting time	25S
Oil reservoir	5L

* Machine shown with optional equipment. Actual product appearance may differ.

SCISSOR LIFT

1000KG
Lifting Capacity

Hydraulic
Driven System
Smooth Running

Versatile
Applicable To Motorcycles, ATVs,
Lawn Mower etc.



A Pneumatic release

With optional front extension

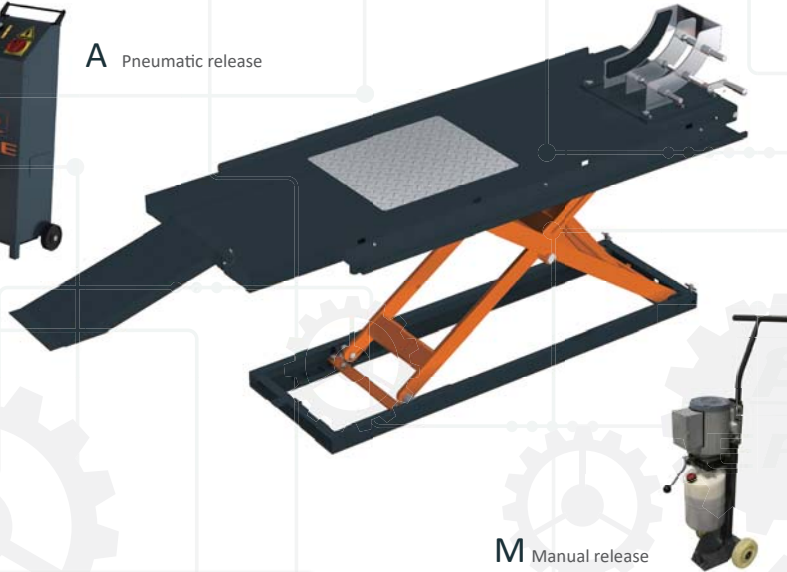

M Manual release

OVERALL DIMENSION

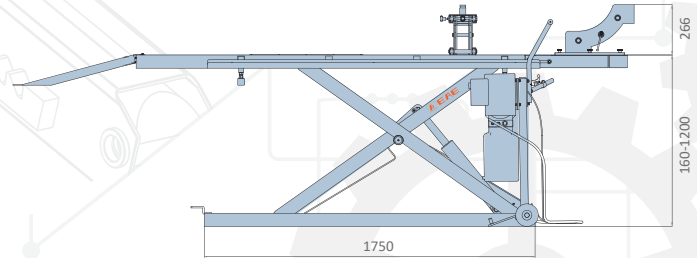
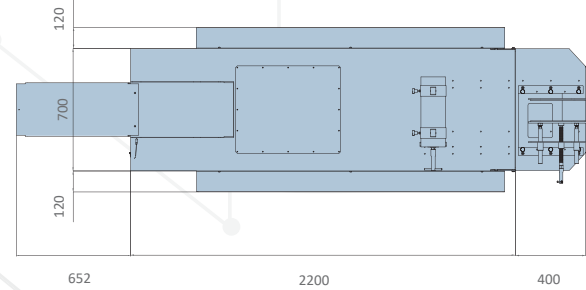

TECHNICAL DATA

MODEL NO	EE-MLH1000
Lifting capacity	1000kg
Max lifting height	1200mm
Standard Platform Size (LxW)	2200mmx700mm
Platform Length With Front Extension	2600mm
Platform Width With Side Extension	1250mm
Platform Width With Extra Side Extension	1540mm
Working Pressure	18-22MPa
Pneumatic Working Pressure	6-8bar
Net Weight	250kg
Electricity supply	According To Customer Needs

* Machine shown with optional equipment. Actual product appearance may differ.



Anti-abrasion Slider



Tool Tray



Optional scissor jack with different adapters.



Hydraulic driven system, smooth running, no swaying when loading on the platform.



16 9/16" (420mm) Optional side extensions for ATVs, lawn mower etc.



Mechanical safety lock



Pneumatic wheel clamping device (optional)



Manual front wheel clamping device (standard)



EE-MLH1000
HYDRAULIC LIFTING TABLE

- Hydraulic driven system, smooth running, no swaying when loading on the platform.
- 1000kg lifting capacity, 1,200mm lifting height.
- Long platform with rear wheel drop cut.
- Manual front wheel clamping device.
- Optional pneumatic front wheel clamping device.
- Standard scissor jack with different adapters.
- Optional side extensions for ATVs, lawn mower etc.
- Manual release and pneumatic release can be available.

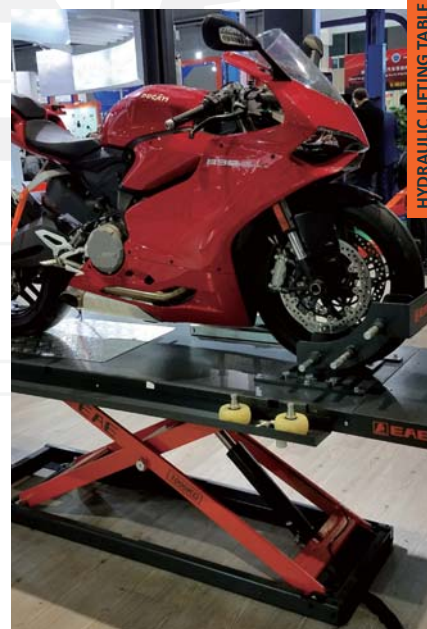

HYDRAULIC LIFTING TABLE

15000KG-45000KG
Lifting Capacity

8000MM
Long Runways of Each Platform

Digital Data
Reading Monitor



EE-HX15/15T



EE-HX30/30T

OVERALL DIMENSION

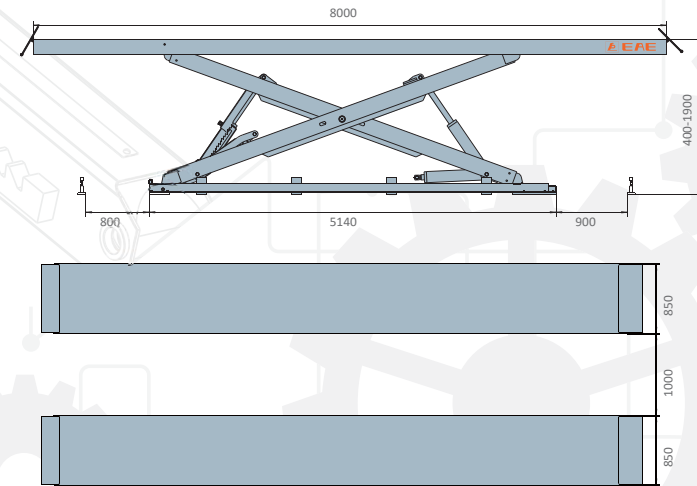

TECHNICAL DATA

MODEL NO.	EE-HX15
Lifting capacity	15000kg
Max. lifting height	1900mm
Min. height	400mm
Platform width	850mm
Complete rise time under rated load	120S
Complete descent time under rated load	100S
Rated oil pressure	22MPa
Oil reservoir	45L
Air supply	6-8bar
Electricity supply	According To Customer Needs
Phase	3Ph
Motor power	3.5kWx2



HEAVY DUTY LIFT



EE-HX SERIES
HEARY DUTY SCISSOR LIFT

- Hydraulic synchronization by four cylinders. The mechanical safety locking unit automatically releases before descending.
- Safe low control voltage (24V) for all control buttons and switches.
- Constantly read the height and working status of each platform through visual monitor.
- Thanks to the CLOSED-LOOP control system, the two platforms automatically align with each other during every rising and lowering cycles. In normal working, the height deviation is limited within 20mm.
- The lifting system stops working in case that the height deviation exceeds 20mm.
- At most 6 platforms can work together synchronously.



Constantly read the height and working status of each platform through visual monitor.



Limit switch to ensure the cylinders work within its maximal stroke.



Laser distance sensor



4-cylinder synchronizing structure

* Machine shown with optional equipment. Actual product appearance may differ.

10T | **STM32** | **Wireless**
 Lifting Capacity of Each Column | Microchip Technology | or with Cables Connecting



EE-HDM10 SERIES

MOBILE COLUMN VEHICLE LIFTS

- Maximum 10000kg capacity per column.
- Set up multiple combinations (2,4, 6 or 8 columns) using an ID card for safe and authorised use.
- Communicate wirelessly by WLAN or be connected by cables.
- No interference from external networks.
- Double safety guaranteed by mechanical and hydraulic locking systems.
- Synchronization automatically achieves by using STM32 microchip technology in the control system.
- Visually and constantly monitor synchronization through man-machine interface technology.
- Highly precise sensor accurately detects the rising height of each column.
- Charger with quality of industrial grade, batteries with large capacity ensures longer service time.
- 24V safe control system and 12V safe power system.
- Adjustable wheel pick-up fork accommodates most of wheels.
- Movable columns help you work efficiently and comfortably.



Constantly monitor the performance of the lift with man-machine interface technology.

Solo identity reader for authorized setting-up.



NO interference from external networks with wireless Wi-Fi communication.

Detect and feedback height with accurate LASER sensors.



Adjustable wheel pick-up fork accommodates most of wheels.

Stands

OVERALL DIMENSION

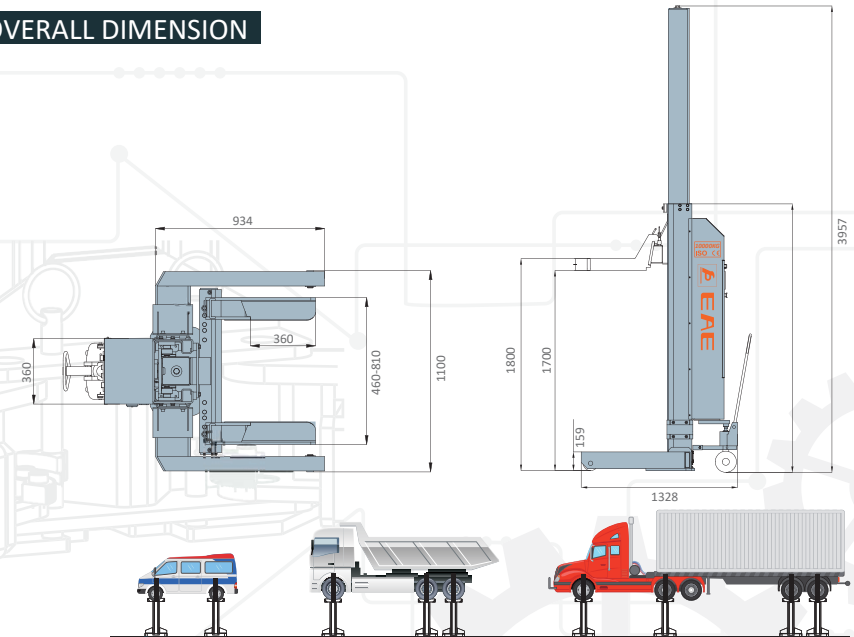

HDM SERIES

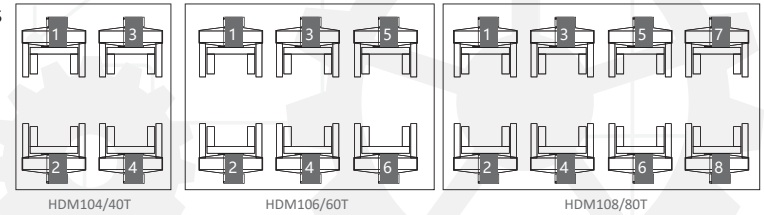

TECHNICAL DATA

MODEL NO.	EE-HDM104
Lifting capacity	10000kgx4
Locking release	Electric
Max. lifting height	1800mm
Min. height	159mm
Full-rise time under rated load	100s
Rated oil pressure	15MPa
Oil reservoir	18Lx4
Voltage control	DC24V
Motor running voltage	DC12Vx4
Motor power	2.2kWx4
Approximate Tire Size	500-1200mm

* Machine shown with optional equipment. Actual product appearance may differ.



HEAVY DUTY LIFT

4000KG/4500KG/5500KG
Lifting Capacity

One Side Operation
More Convenient



One Side Safety
Locks Release



Pulley with
Derailment Protection



Height Adapter



Round Screw-up Lifting Pad



Door Protection Pads



EE-C9/C10/C12

TWO POST LIFT

- 4000kg/4500kg/5500kg lifting capacity.
- Single side release for mechanical safety locking unit.
- Cylinder straight top device, run more smoothly.
- Durable cylinders in each column carry with anti-surge valves.
- With vehicle roof protection. The power system switches off when vehicle roof touches the rubber protected overhead bar.
- Standard door protection pads to prevent possible damage to the door opened without caution.
- Pre-fixed hydraulic pressure prevents overloading operation.
- Standard chain protection curtain.

OVERALL DIMENSION

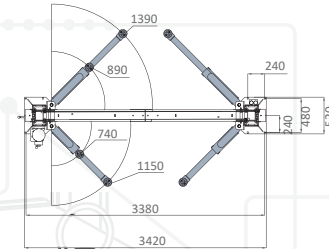

EE-C9

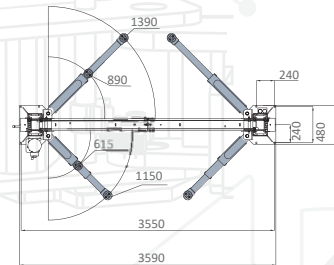

EE-C10

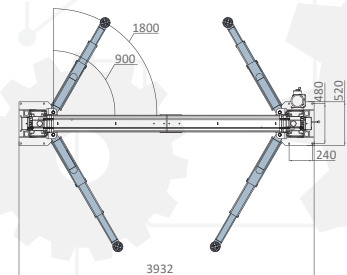

EE-C12

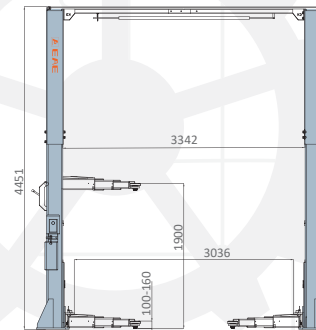
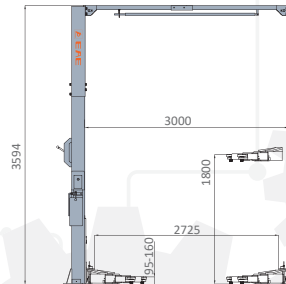
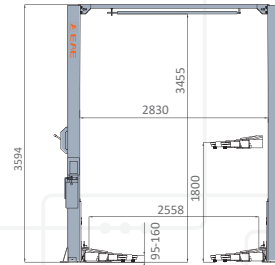

TECHNICAL DATA

MODEL NO.	EE-C9	EE-C10	EE-C12
Lifting capacity	4000kg	4500kg	5500kg
Max lifting height	1800mm	1800mm	1900mm
Min height	95mm	95mm	100mm
Lifting time	55S	55S	55S
Capacity of motor	2.2kW	2.2kW	2.2kW
Rated oil pressure	18MPa	19MPa	21MPa
Drive through	2830mm	3000mm	3342mm
Overall Height	3594mm	3900mm	4451mm
Electricity supply	According To Customer Needs	According To Customer Needs	According To Customer Needs

* Machine shown with optional equipment. Actual product appearance may differ.

4000KG/4500KG/5500KG
Lifting Capacity

One Side Operation
More Convenient



OVERALL DIMENSION

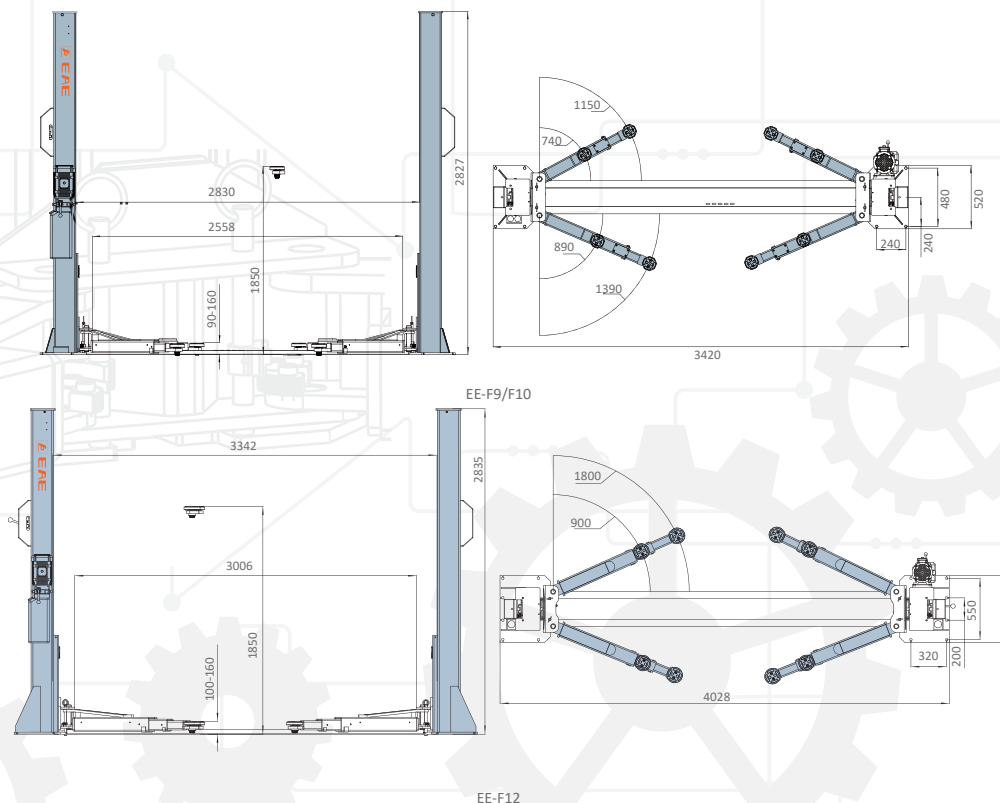

TECHNICAL DATA

MODEL NO.	EE-F9	EE-F10	EE-F12
Lifting capacity	4000kg	4500kg	5500kg
Max lifting height	1850mm	1850mm	1850mm
Min height	90mm	90mm	100mm
Lifting time	45S-55S	45S-55S	45S-55S
Capacity of motor	2.2kW	2.2kW	2.2kW
Rated oil pressure	18MPa	22MPa	23MPa
Drive through	2830mm	2830mm	3342mm
Overall Height	2827mm	2827mm	2835mm
Electricity supply	According To Customer Needs	According To Customer Needs	According To Customer Needs

* Machine shown with optional equipment. Actual product appearance may differ.



One Side Safety Locks Release



Door Protection Pads



EE-F9/F10/F12

TWO POST LIFT

- 4000kg/4500kg/5500kg lifting capacity.
- Single side release for mechanical safety locking unit.
- Durable cylinders in each column carry with anti-surge valves.
- Standard door protection pads to prevent possible damage to the door opened without caution.
- Pre-fixed hydraulic pressure prevents overloading operation.
- Standard chain protection curtain.



Height Adapter



Round Screw-up Lifting Pad

3000KG
Lifting Capacity

Two Parking Lifts
Share One Power Unit

Space Saving
Less Investment



EE-64P2

MULTIPLE COMBINATION PARKING LIFT

- It can be installed in car sales shops, workshops, community supermarket, for classical car collection storage and so on.
- It is much more space saving, less investment and easier maintenance because of the unique design that two parking lifts share one power unit.
- The two units staying adjacent are connected by bolts at the top and secured with expansion bolts at the bottom. It is not only space saving, but also ensures stability.
- Removable drive-on ramps can fix on either end upon practical needs.
- 3000kg lifting capacity, 1850mm lifting height.
- Built-in robust and reliable mechanical lock and release devices make it also look comfortable
- Easy on-site installation and less demanding on foundation.
- 24V safety control voltage.
- Optional aluminum alloy decking make the parking area as a whole. Small vehicles like motorcycle, ATV, lawn mower can park on it.
- Optional oil drip pan.
- Zinc-coating pulleys with bronze bushings of advanced quality.

OVERALL DIMENSION

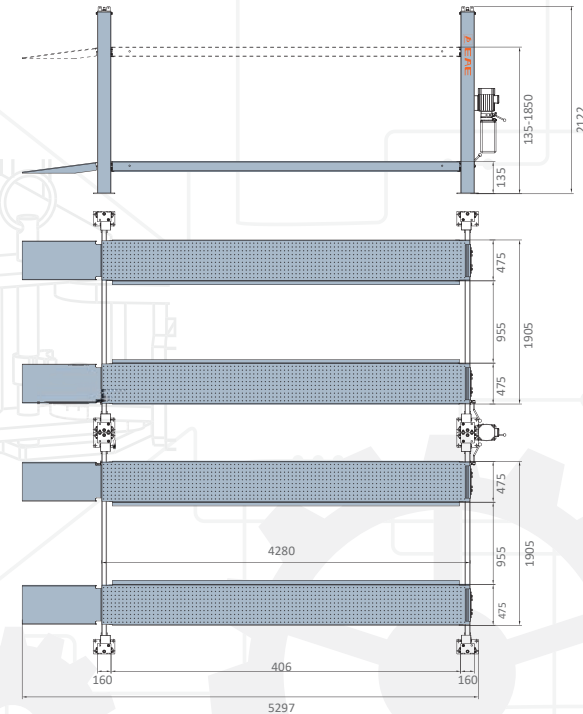

TECHNICAL DATA

MODEL NO.	EE-64P2
Lifting capability	3000kg
Total height	2174mm
Total length	5300mm
Total width	2570mm
Platform length	4270mm
Inter-column width	2400mm
Into the car width	2300mm
Wheelbase range	≤3500mm
Track range	1200-1650mm
Min height	135mm
Rated oil pressure	18MPa
Weight	750kg

* Machine shown with optional equipment. Actual product appearance may differ.



24V control box



The two units staying adjacent are connected by bolts at the top and secured with expansion bolts at the bottom. It is not only space saving, but also ensures stability.



Built-in robust and reliable mechanical lock and release devices make it also look comfortable.



Wire rope Hydro-cylinder

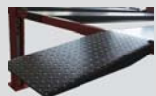

Removable drive-on ramps can fix on either end upon practical needs.

8000kg
Heavy Duty
Lifting Capacity

4900MM
Other Height
Available Upon Request

2080MM
Max. Lifting Height
with Standard SUV Adapters



OVERALL DIMENSION

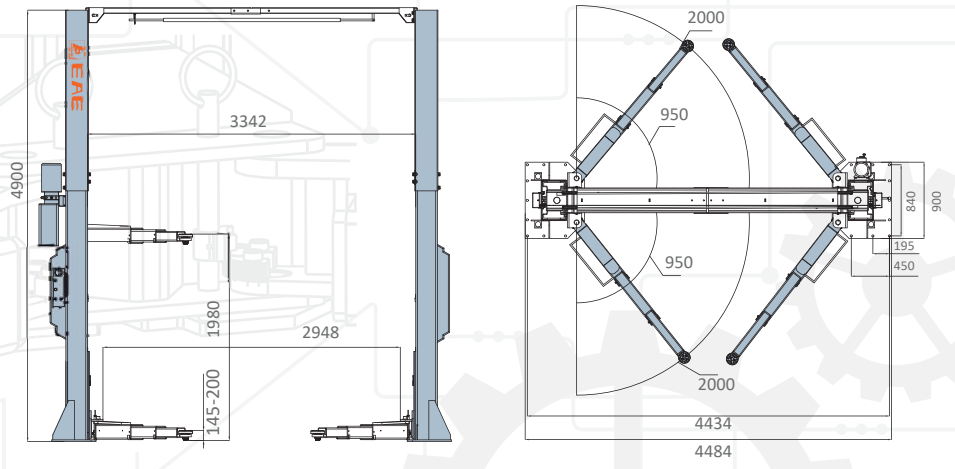

TECHNICAL DATA

MODEL NO.	EE-C18E
Lifting capacity	8,000kg
Max lifting height	1980mm
Min height	145mm
Lifting time	80S
Motor	3.5kW
Rated oil pressure	20MPa
Drive-through width	2948mm
Weight	2650kg
Electricity supply	According To Customer Needs

* Max. Lifting height is measured with adjustable screw pads in highest position.
* Machine shown with optional equipment. Actual product appearance may differ.



EE-C18E
HEAVY DUTY TWO POST LIFT

- 8000kg lifting capacity.
- 1980mm lifting height.
- Electrical release, simply press Up and Down button to operate the lift.
- Cylinder straight top device, run more smoothly.
- Clear floor design for easy movement of maintenance equipment under the raised vehicle.
- Durable cylinders in each column carry with anti-surge valves.
- Screw-up lifting pads with clearance height less than 145mm.
- The arm locks engage and disengage automatically.
- With vehicle roof protection. The power system switches off when vehicle roof touches the rubber protected overhead bar.
- Aluminum motor avoids overheating and ensures long service life.
- Standard door protection pads to prevent possible damage to the door opened without caution.
- Pre-fixed hydraulic pressure prevents overloading operation.
- ABS control box with rubber gasket sealing.



15000KG-45000KG
Lifting Capacity

8000MM
Long Runways of Each Platform

Digital Data
Reading Monitor



EE-HX15/15T



EE-HX30/30T

OVERALL DIMENSION

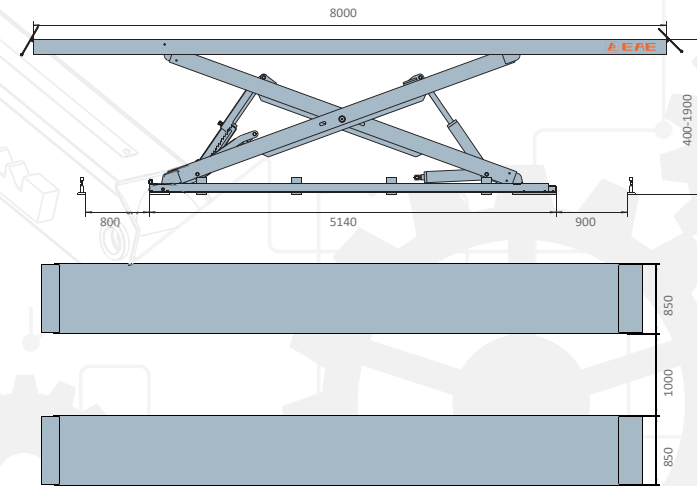

TECHNICAL DATA

MODEL NO.	EE-HX15
Lifting capacity	15000kg
Max. lifting height	1900mm
Min. height	400mm
Platform width	850mm
Complete rise time under rated load	120S
Complete descent time under rated load	100S
Rated oil pressure	22MPa
Oil reservoir	45L
Air supply	6-8bar
Electricity supply	According To Customer Needs
Phase	3Ph
Motor power	3.5kWx2



HEAVY DUTY LIFT



EE-HX SERIES
HEARY DUTY SCISSOR LIFT

- Hydraulic synchronization by four cylinders. The mechanical safety locking unit automatically releases before descending.
- Safe low control voltage (24V) for all control buttons and switches.
- Constantly read the height and working status of each platform through visual monitor.
- Thanks to the CLOSED-LOOP control system, the two platforms automatically align with each other during every rising and lowering cycles. In normal working, the height deviation is limited within 20mm.
- The lifting system stops working in case that the height deviation exceeds 20mm.
- At most 6 platforms can work together synchronously.



Constantly read the height and working status of each platform through visual monitor.



Limit switch to ensure the cylinders work within its maximal stroke.



Laser distance sensor



4-cylinder synchronizing structure

* Machine shown with optional equipment. Actual product appearance may differ.

10T | **STM32** | **Wireless**
 Lifting Capacity of Each Column | Microchip Technology | or with Cables Connecting



EE-HDM10 SERIES

MOBILE COLUMN VEHICLE LIFTS

- Maximum 10000kg capacity per column.
- Set up multiple combinations (2,4, 6 or 8 columns) using an ID card for safe and authorised use.
- Communicate wirelessly by WLAN or be connected by cables.
- No interference from external networks.
- Double safety guaranteed by mechanical and hydraulic locking systems.
- Synchronization automatically achieves by using STM32 microchip technology in the control system.
- Visually and constantly monitor synchronization through man-machine interface technology.
- Highly precise sensor accurately detects the rising height of each column.
- Charger with quality of industrial grade, batteries with large capacity ensures longer service time.
- 24V safe control system and 12V safe power system.
- Adjustable wheel pick-up fork accommodates most of wheels.
- Movable columns help you work efficiently and comfortably.



Constantly monitor the performance of the lift with man-machine interface technology.

Solo identity reader for authorized setting-up.



NO interference from external networks with wireless Wi-Fi communication.

Detect and feedback height with accurate LASER sensors.



Adjustable wheel pick-up fork accommodates most of wheels.

Stands

OVERALL DIMENSION

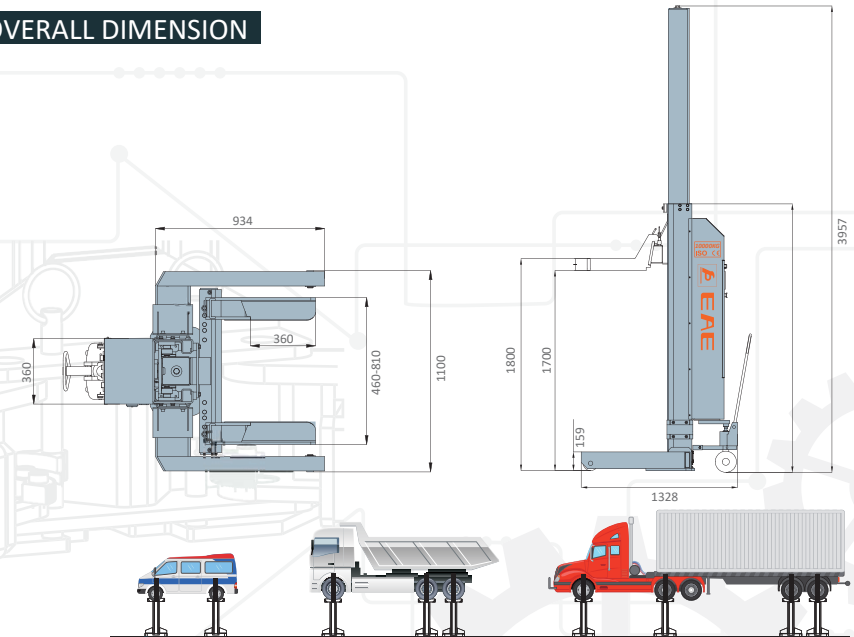

HDM SERIES

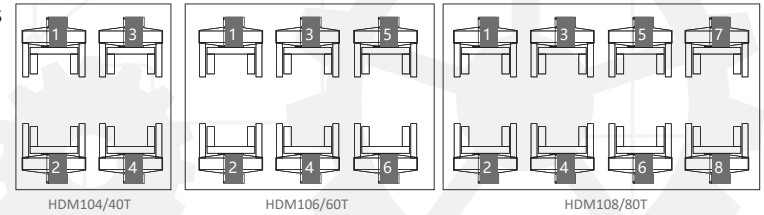

TECHNICAL DATA

MODEL NO.	EE-HDM104
Lifting capacity	10000kgx4
Locking release	Electric
Max. lifting height	1800mm
Min. height	159mm
Full-rise time under rated load	100s
Rated oil pressure	15MPa
Oil reservoir	18Lx4
Voltage control	DC24V
Motor running voltage	DC12Vx4
Motor power	2.2kWx4
Approximate Tire Size	500-1200mm

* Machine shown with optional equipment. Actual product appearance may differ.



HEAVY DUTY LIFT

4000KG/4500KG/5500KG
Lifting Capacity

One Side Operation
More Convenient



One Side Safety
Locks Release



Pulley with
Derailment Protection



Height Adapter



Round Screw-up Lifting Pad



Door Protection Pads



EE-C9/C10/C12

TWO POST LIFT

- 4000kg/4500kg/5500kg lifting capacity.
- Single side release for mechanical safety locking unit.
- Cylinder straight top device, run more smoothly.
- Durable cylinders in each column carry with anti-surge valves.
- With vehicle roof protection. The power system switches off when vehicle roof touches the rubber protected overhead bar.
- Standard door protection pads to prevent possible damage to the door opened without caution.
- Pre-fixed hydraulic pressure prevents overloading operation.
- Standard chain protection curtain.

OVERALL DIMENSION

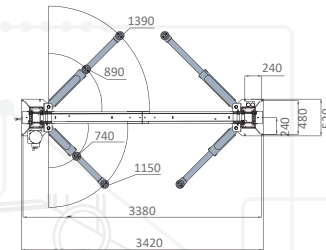

EE-C9

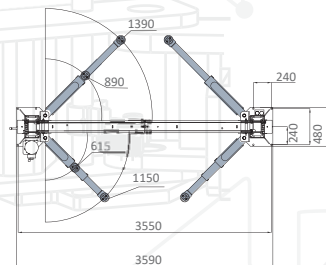

EE-C10

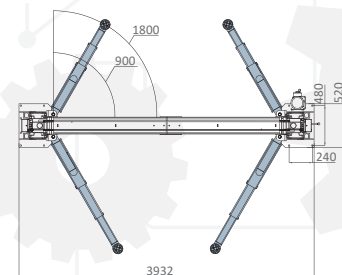

EE-C12

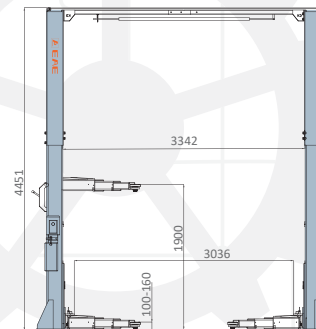
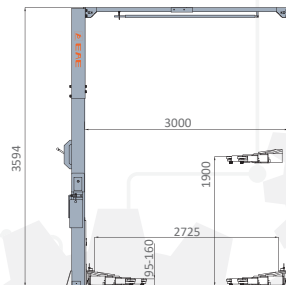
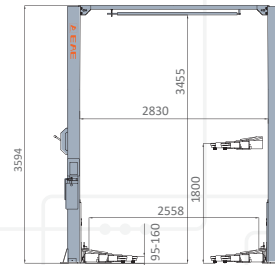

TECHNICAL DATA

MODEL NO.	EE-C9	EE-C10	EE-C12
Lifting capacity	4000kg	4500kg	5500kg
Max lifting height	1800mm	1900mm	1900mm
Min height	95mm	95mm	100mm
Lifting time	55S	55S	55S
Capacity of motor	2.2kW	2.2kW	2.2kW
Rated oil pressure	18MPa	19MPa	21MPa
Drive through	2830mm	3000mm	3342mm
Overall Height	3594mm	3900mm	4451mm
Electricity supply	According To Customer Needs	According To Customer Needs	According To Customer Needs

* Machine shown with optional equipment. Actual product appearance may differ.

4000KG/4500KG/5500KG
Lifting Capacity

One Side Operation
More Convenient



OVERALL DIMENSION

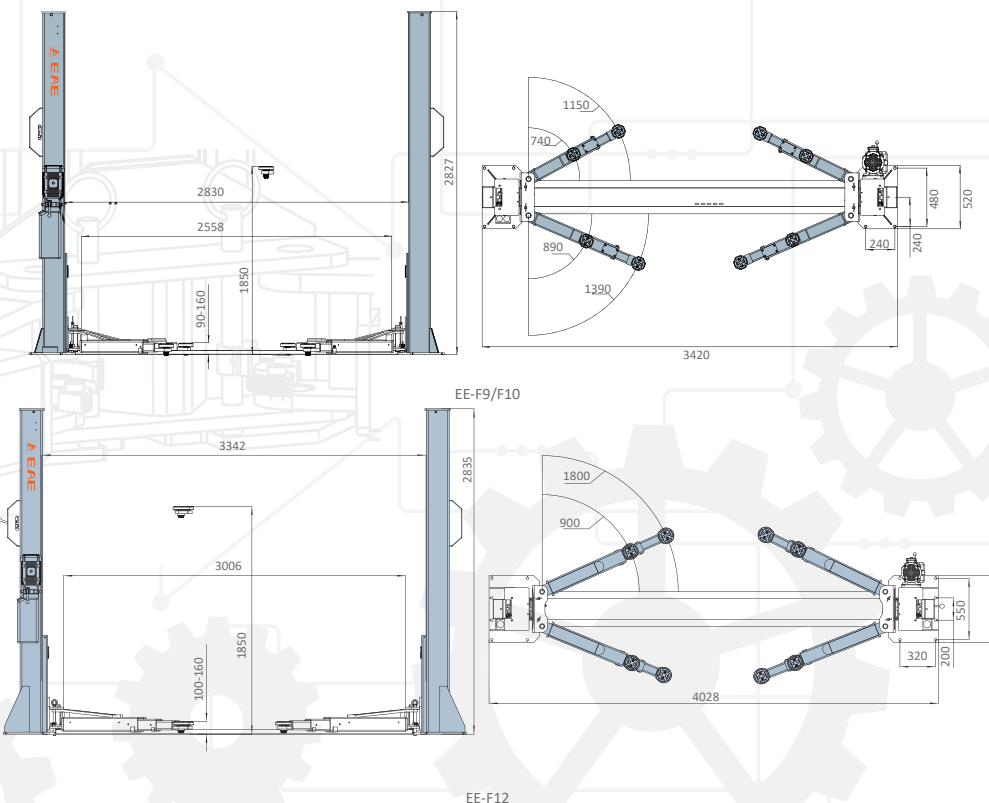

TECHNICAL DATA

MODEL NO.	EE-F9	EE-F10	EE-F12
Lifting capacity	4000kg	4500kg	5500kg
Max lifting height	1850mm	1850mm	1850mm
Min height	90mm	90mm	100mm
Lifting time	45S-55S	45S-55S	45S-55S
Capacity of motor	2.2kW	2.2kW	2.2kW
Rated oil pressure	18MPa	22MPa	23MPa
Drive through	2830mm	2830mm	3342mm
Overall Height	2827mm	2827mm	2835mm
Electricity supply	According To Customer Needs	According To Customer Needs	According To Customer Needs

* Machine shown with optional equipment. Actual product appearance may differ.



One Side Safety Locks Release



Door Protection Pads



EE-F9/F10/F12

TWO POST LIFT

- 4000kg/4500kg/5500kg lifting capacity.
- Single side release for mechanical safety locking unit.
- Durable cylinders in each column carry with anti-surge valves.
- Standard door protection pads to prevent possible damage to the door opened without caution.
- Pre-fixed hydraulic pressure prevents overloading operation.
- Standard chain protection curtain.



Height Adapter



Round Screw-up Lifting Pad

3000KG
Lifting Capacity

Two Parking Lifts
Share One Power Unit

Space Saving
Less Investment

OVERALL DIMENSION



EE-64P2

MULTIPLE COMBINATION PARKING LIFT

- It can be installed in car sales shops, workshops, community supermarket, for classical car collection storage and so on.
- It is much more space saving, less investment and easier maintenance because of the unique design that two parking lifts share one power unit.
- The two units staying adjacent are connected by bolts at the top and secured with expansion bolts at the bottom. It is not only space saving, but also ensures stability.
- Removable drive-on ramps can fix on either end upon practical needs.
- 3000kg lifting capacity, 1850mm lifting height.
- Built-in robust and reliable mechanical lock and release devices make it also look comfortable
- Easy on-site installation and less demanding on foundation.
- 24V safety control voltage.
- Optional aluminum alloy decking make the parking area as a whole. Small vehicles like motorcycle, ATV, lawn mower can park on it.
- Optional oil drip pan.
- Zinc-coating pulleys with bronze bushings of advanced quality.

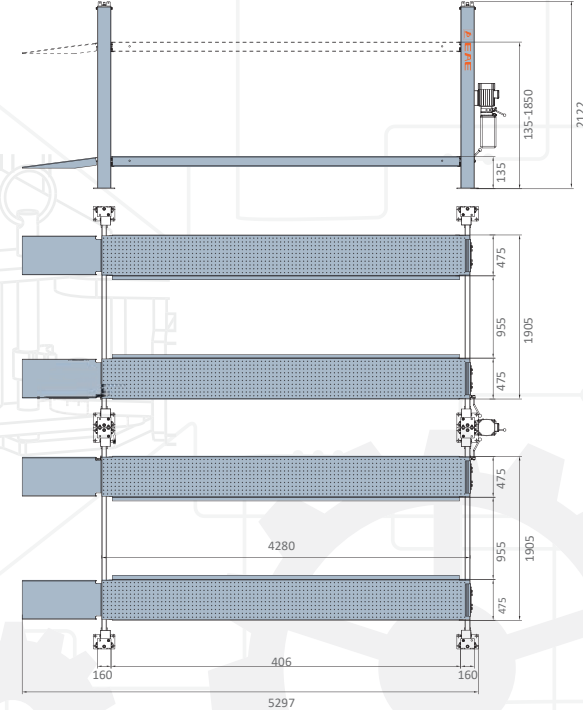

TECHNICAL DATA

MODEL NO.	EE-64P2
Lifting capability	3000kg
Total height	2174mm
Total length	5300mm
Total width	2570mm
Platform length	4270mm
Inter-column width	2400mm
Into the car width	2300mm
Wheelbase range	≤3500mm
Track range	1200-1650mm
Min height	135mm
Rated oil pressure	18MPa
Weight	750kg

* Machine shown with optional equipment. Actual product appearance may differ.



24V control box



The two units staying adjacent are connected by bolts at the top and secured with expansion bolts at the bottom. It is not only space saving, but also ensures stability.



Built-in robust and reliable mechanical lock and release devices make it also look comfortable.



Wire rope Hydro-cylinder

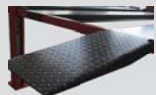

Removable drive-on ramps can fix on either end upon practical needs.